



OPERATION AND MAINTENANCE MANUAL

DOCUMENT TITLE: Operation and Maintenance Manual Electric Torque Tool Class 1
- 4

PROJECT TITLE: 8.1. ISO 1 to 4-Mech.Interfaces

PROJECT: 600144

DOCUMENT NUMBER: 600144-TD-0003

REV: 06

NUMBER OF PAGES: 1 of 86

DATE: 07.02.2020

CLIENT:

CLIENT PO:

CLIENT CONTACT:

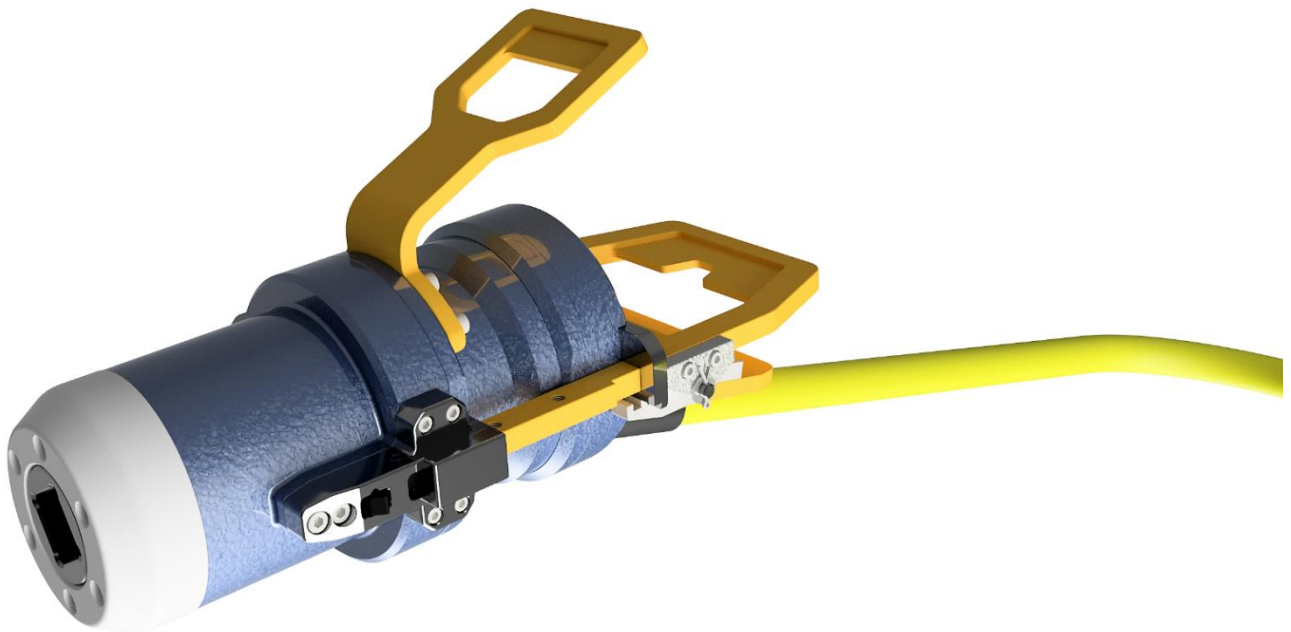



REVISION CHANGE/RECORD

REV	REASON FOR REVISION/ DESCRIPTION OF CHANGES
01	Document initiated for use
02	Re-issued for use
03	Re-issued with configuration fix
04	Added info on 2Kw Subsea USB Connector, 230VAC & .xls graph output reporting
05	Added safety information
06	Complete restructure of manual. Added pin config for PFC-ROV cable



TABLE OF CONTENT

- 1. INTRODUCTION 6**
 - 1.1. PURPOSE AND SCOPE 6
 - 1.2. ABBREVIATIONS..... 6
 - 1.3. SYMBOLS 7
 - 1.4. WARRANTY CONDITIONS AND GUARANTEES..... 7
 - 1.5. REFERENCES..... 7

- 2. HEALTH, SAFETY AND ENVIRONMENT 8**
 - 2.1. PERSONAL PROTECTIVE EQUIPMENT 8
 - 2.2. QUALIFICTIONS AND TRAINING..... 8

- 3. SYSTEM OVERVIEW..... 9**
 - 3.1. BB0062 - 2,7KNM TORQUE TOOL KIT 9
 - 3.1.1. Technical Description for Electrical Torque Tool.....11
 - 3.1.1.1. Technical Data.....12
 - 3.1.1.2. Interface Description.....13
 - 3.1.1.3. Locking System 15
 - 3.1.1.4. Position Feedback17
 - 3.1.1.5. Performance Data..... 18
 - 3.1.1.6. EI Power Can 19
 - 3.2. BA8949, BB3151 - 2,7KNM TORQUE TOOL KIT W/INDUCTIVE CONNECTOR 22
 - 3.2.1. Technical Description for Electrical Torque Tool..... 24
 - 3.2.1.1. Technical Data..... 24
 - 3.2.1.2. Interface Description..... 24
 - 3.2.1.3. Locking System 24
 - 3.2.1.4. Position Feedback 24
 - 3.2.1.5. Performance Data..... 24
 - 3.2.2. Technical Description Inductive Coupler..... 25
 - 3.2.2.1. Technical Data..... 26
 - 3.2.2.2. Interface Description Secondary Side Connector27
 - 3.2.2.3. Interface Description ROV-PFC..... 28

- 4. TOPSIDE CONTROL SOFTWARE.....29**
 - 4.1. GUI..... 29
 - 4.1.1. Main Window..... 29
 - 4.1.2. Main Window Information Boards31
 - 4.1.3. Setup Window 33
 - 4.1.4. Setup Window Sections 35
 - 4.1.5. Operational Modes 38

- 5. AUXILIARY EQUIPMENT 41**
 - 5.1. EQUIPMENT MATRIX.....41



- 6. MOBILISATION/DE-MOBILISATION42**
 - 6.1. ONSHORE PREPARATIONS 42
 - 6.2. MOBILISATION PROCEDURE 43
 - 6.3. DE-MOBILISATION PROCEDURE..... 43

- 7. OPERATION44**
 - 7.1. TOPSIDE OPERATION 44
 - 7.2. OFFSHORE PREPARATIONS 44
 - 7.2.1. Pre Dive Check 44
 - 7.2.2. Changing the ISO Key 45
 - 7.3. PRE-DIVE OPERATION STARTUP 46
 - 7.3.1. Check Setup Settings..... 46
 - 7.3.2. Torque Class Detection47
 - 7.3.3. Add Archiving Information..... 48
 - 7.4. SUBSEA OPERATION 49
 - 7.5. POST DIVE CHECK 50
 - 7.6. HOOK-UP AND COMMUNICATION 51
 - 7.7. ELTT OPERATION 52
 - 7.7.1. Operational Controls..... 52
 - 7.7.2. Unit settings..... 53
 - 7.7.3. Adjustment Operations 54
 - 7.7.4. Torque and Speed Monitoring (Meters) 55
 - 7.7.5. Reset Socket Position..... 55
 - 7.7.6. Diagnostics and Restart..... 56
 - 7.7.7. Error Shut Down Override Function 57
 - 7.8. XLS TORQUE REPORTING 58
 - 7.8.1. Generate Operation Report (PDF) 58
 - 7.8.2. Save or Print Report..... 60
 - 7.8.3. Load Graph from File..... 61
 - 7.8.4. Report Front Page..... 62
 - 7.8.5. Chart..... 63
 - 7.8.6. Automatic Filename Calculation 64
 - 7.8.7. Change Log..... 65
 - 7.9. PREDEFINED OPERATIONS 66
 - 7.9.1. Save to/load from Files..... 66
 - 7.9.2. Preparation of Configuration Files for Each Activity67

- 8. TROUBLE SHOOTING.....69**
 - 8.1. GENERAL 69
 - 8.2. LOSS OF CONFIGURATION 69
 - 8.2.1. Generate New Backup File..... 70
 - 8.3. TROUBLE SHOOTING TABLE.....73
 - 8.3.1. Motor Overload 81
 - 8.3.2. Slow Communication..... 82



9. LOGISTICS83

9.1. HANDLING AND LIFTING..... 83

9.2. TRANSPORTATION 83

9.3. STORAGE..... 83

10. MAINTENANCE84

10.1. DAILY INSPECTION 84

10.2. WEEKLEY INSPECTION 84

10.3. MONTHLY INSPECTION 84

10.4. YEARLY INSPECTION AND MAINTENANCE 85

10.5. LATCH MECHANISM – WEAKLINK REPLACEMENT 85

11. SUPPORT CONTACT 86



1. INTRODUCTION

1.1. PURPOSE AND SCOPE

The objective of this document is to present a comprehensive user manual for the Blue Logic Electrical Torque Tool (ELTT). Relevant technical aspects for information and familiarization are covered as well as detailed technical data.

The Blue Logic Electrical Torque Tool System (ELTTS) is designed as a compact and accurate multipurpose Torque Tool System designed for all typical Subsea Torque Tool operations

This OMM covers the following specific Torque Tool kits:

Art. No.:	Description:
BB0062	2,7kNm Torque Tool Kit
BA8949	2,7kNm Torque Tool Kit wInductive Connector
BB3151	2kW Subsea USB Kit for Electrical Torque Tool

1.2. ABBREVIATIONS

ELTT	=	Electrical Torque Tool
ELTTS	=	Electrical Torque Tool System
EPC	=	Electrical Power Can
GUI	=	Graphical User Interface
IC	=	Inductive Coupler
OMM	=	Operation and Maintenance Manual
ROV	=	Remotely Operated Vehicle
TT	=	Torque Tool
EFR	=	Equipment Failure Report
CP	=	Cathodic Protection
PFC	=	Power Factor Control
CW	=	Clockwise
CCW	=	Counter Clockwise



OPERATION AND MAINTENANCE MANUAL

1.3. SYMBOLS

The following words and symbols found throughout this manual, highlights special messages to alert the operator of specific information.



WARNING: The equipment to which this manual applies must only be used for the purpose for which it was designed. Improper use or maintenance may cause damage to the equipment and/or injury to personnel. All users must be familiar with the contents of the appropriate manuals before attempting to install, operate, maintain or in any other way work on the equipment. Blue Logic AS disclaims any responsibility for damage or injury caused by improper installation, use or maintenance of the equipment.



CAUTION: The equipment to which this manual applies operates on high voltage, and has the potential to results in death or severe injury if handled incorrect. The equipment should only be used by qualified personnel. The equipment contains no serviceable parts inside.

1.4. WARRANTY CONDITIONS AND GUARANTEES

It is the responsibility of the end user to make sure that the product is used in such a manner for which it is designed. This includes accounting for material/fluid compatibility, sour service, temperature, pressure rating etc.

When performing operation above water do not run tool on full load for prolonged periods. Consider water-cooling if operation is expected to take time. Consider ambient temperature.

1.5. REFERENCES

Latest version of the following documents

Id.	Doc. No	Originator	Document Title
/01/	BB0062	Blue Logic	2,7kNm Torque Tool Kit
/02/	BA8949	Blue Logic	2,7kNm Torque Tool Kit wInductive Connector
/03/	600128-TD-0013	Blue Logic	Operation and Maintenance Manual 2KW Subsea USB System
/04/	BB3151	Blue Logic	2kW Subsea USB Kit for Electrical Torque Tool
/05/	600144-TD-0008	Blue Logic	ETT Check List Mob/Demob

2. HEALTH, SAFETY AND ENVIRONMENT

Safety must always be the highest priority when performing operations, maintenance and tests when using the ELTT.

Personnel involved in the test/work operation shall be familiar with the contents of this document.

2.1. PERSONAL PROTECTIVE EQUIPMENT

The following minimum PPE must be worn when operating the ELTT

Personal Protective Equipment
Protective glasses
Protective shoes
Protective gloves

2.2. QUALIFICTIONS AND TRAINING

It is essential that all operating personnel have been given training and education, in how to operate and maintain the equipment described in this manual.

3. SYSTEM OVERVIEW

The Electric Torque Tool System is typically supplied in kits containing relevant equipment for use. Although client specific setup and/or kits can be agreed and delivered, there are two available standard kits. In one kit the ELTT is powered by an Electric Power Can (EPC), see Figure 1. In the other kit the ELTT is powered via an inductive Type- C coupler, see Figure 8.

3.1. BB0062 - 2,7KNM TORQUE TOOL KIT



Figure 1: BB0062 Torque Tool Kit

The BB0062 kit consists of:

Item	QTY	Art No.:	Description
1.	1	BA7297	Class 4 Interface Socket Low Torque
2.	1	BA2951	Class 1 & 2 Interface Socket
3.	1	600144-TD-0003	Operation and Maintenance Manual Electric Torque Tool Class 1 - 4
4.	1	102354	Burton Test Cable
5.	1	101819	Moxa Adapter DB9F to TB
6.	1	101817	Pelicans 1495D
7.	1	102858	Laptop HP Probook
8.	1	100687	Moxa UPort 1150I
9.	1	100499	Burton Pigtail*
10.	1	BB108	Alu Box 240L incl. Foams
11.	1	BA274	BA2749 2700 Nm Electrical Torque Tool 3000m
12.	1	10285	Computer Mouse



Item	QTY	Art No.:	Description
13.	1	10285	PC Charger Module
14.	1	10286	Burton Dummy
15.	1	10295	USB Charger Module

***NOTE:**

For rental tools, Item 9 Burton Pigtail, is regarded as consumables and will be invoiced if used in operation.



Figure 2: Electrical Torque Tool powered by EPC

3.1.1. Technical Description for Electrical Torque Tool

The Blue Logic Class 1-4 Electrical Torque Tool (ELTT) is a module designed Torque Tool (TT). The ELTT is a compact, flexible, and robust precision tool for subsea and ROV operations.

The Blue Logic ELTT System combines all known advantages from a hydraulic torque tool system with the technology and advantages from a modern servo based electrical controlled drive system. Also included is an auto detect system which detects what type of *mechanical interface class 1-4 socket* has been installed, and automatically switches between Low Torque (LT) mode and High Torque (HT) mode accordingly.

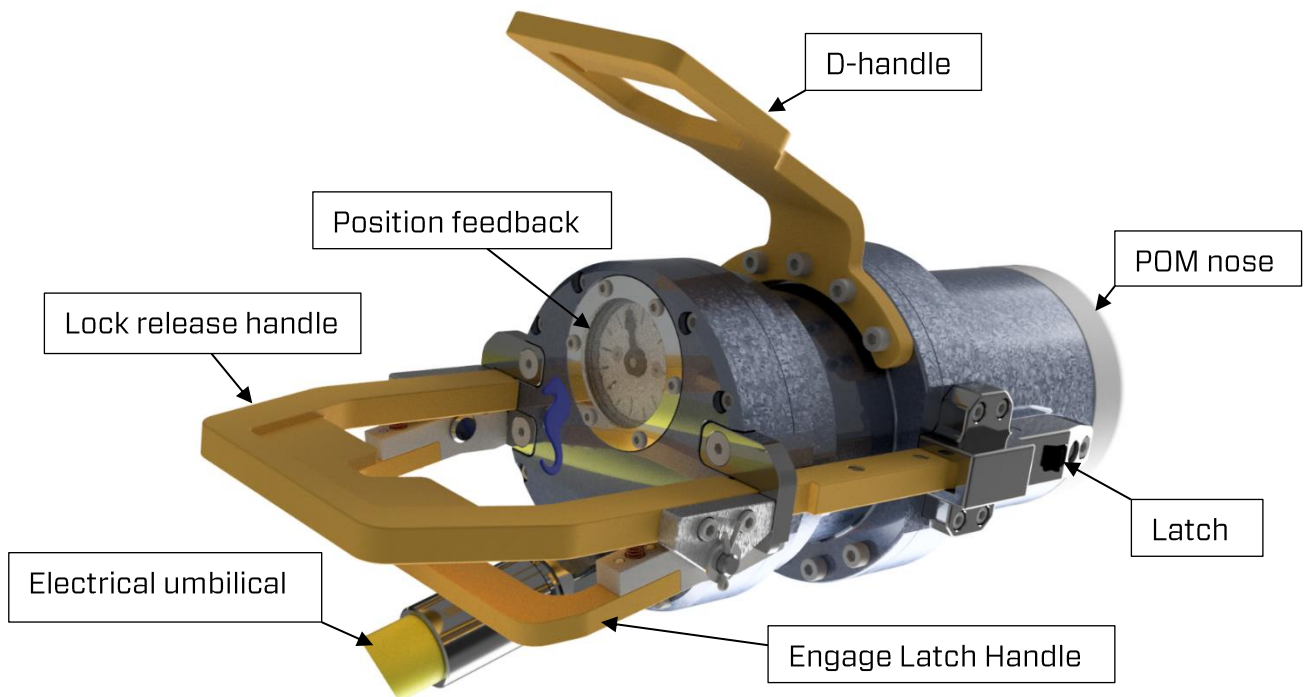

Figure 3: ELTT



HIGH VLOTAGE: The Torque Tool operates on high voltage and has the potential to result in death or severe injury if handled incorrect. The equipment should only be used by qualified personnel. The equipment contains no serviceable parts inside.



WARNING: Rotating parts can be hazardous. Keep hands and body out of the operating area. Failure to follow these warnings could result in death or severe personal injury.

**OPERATION AND MAINTENANCE MANUAL****3.1.1.1. Technical Data***Table 1: Mechanical Data*

Description	Specifications
Depth rating	3000m

Table 2: Oil Data

Description	Specifications
Oil*	Q8 T 65 LS
* The ELTT system is partly oil compensated	

Table 3: Electrical Requirements

Description	Specifications
Power*	2 kW
*To achieve 2700 Nm @ 6 rpm 2kW is required Smaller power supply can be used with reduced maximum speed can be adjusted in Setup. Formula: Power = Output-Torque(Nm) * ((speed(rpm)/60)*6,28)	

Table 4: Minimum ROV Requirements

Description	Specifications
Power	5A 230/115 VAC
Current consumption	20A

Table 5: Communication Data

Description	Specifications
RS232	Default *
* The default communication protocol is RS232, RS485 and Ethernet can be made available upon request	



3.1.1.2. Interface Description

Table 6: Mechanical Interface according to ISO 13628-8

Interface	Class	Torque
ISO	1	67 Nm
ISO	2	271 Nm
ISO	3	1355 Nm
ISO	4	2711 Nm

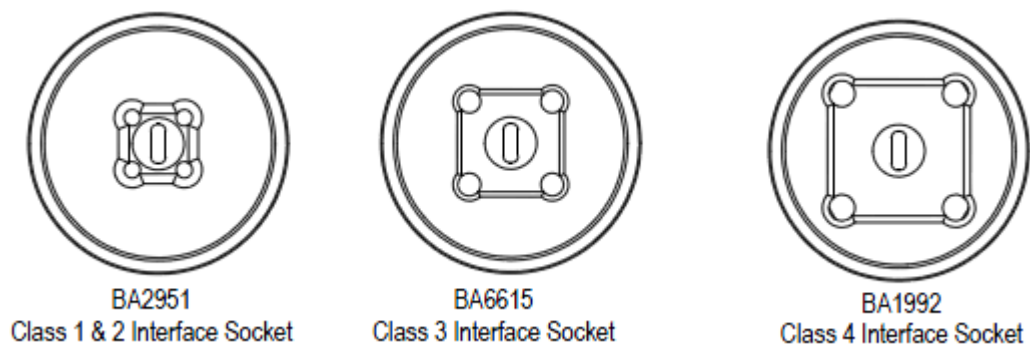

Figure 4: Interface socket class 1 - 4

OPERATION AND MAINTENANCE MANUAL

ELTT has *mechanical interface class 1-4 socket* designed according to ISO 13628-8 valves class 1-4. *Mechanical socket* is easily changed topside by removing the POM Nose. ELTT will automatically switch between High Torque (HT) and Low Torque (LT) mode. Class 1 and 2 valves are operated in Low Torque mode, whereas Class 3 and 4 are operated in High Torque mode. It is not necessary to change the ELTT motor between HT and LT mode.

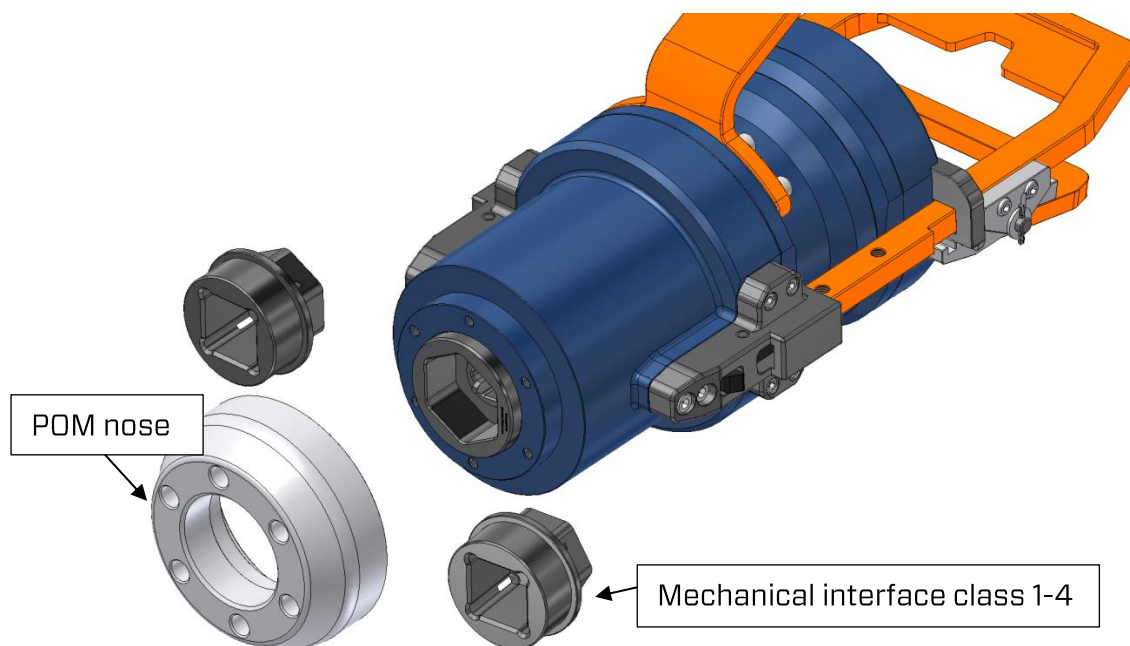

Figure 5: Mechanical Interface socket

To replace the mechanical socket, see section 7.2.2.



3.1.1.3. Locking System

The ELTT locking system is manually operated by use of the ROV manipulator arm. The locking system has three positions, Latch Open, Auto Latch and Latch Locked. The lock is operated by use of a push-pull mechanism connected to the ROV handle.

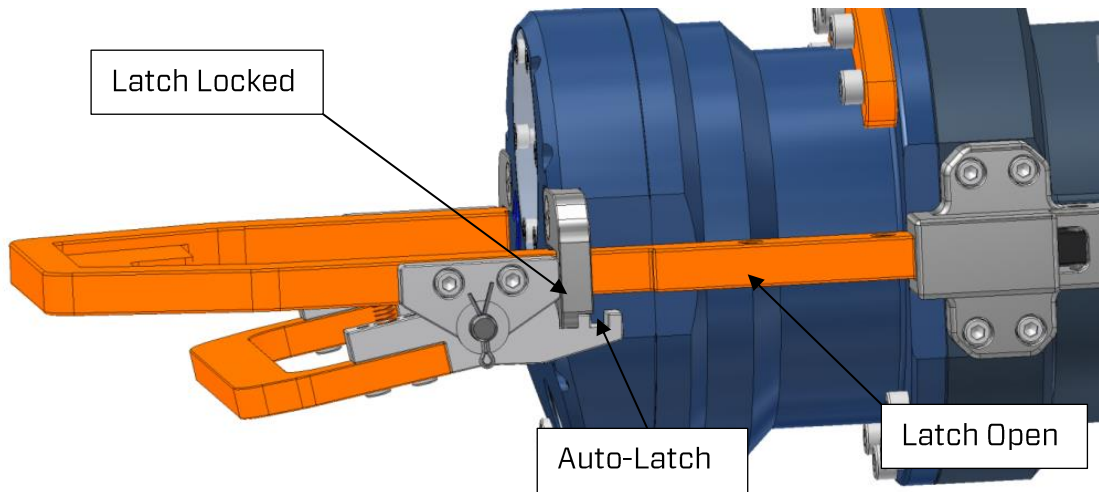
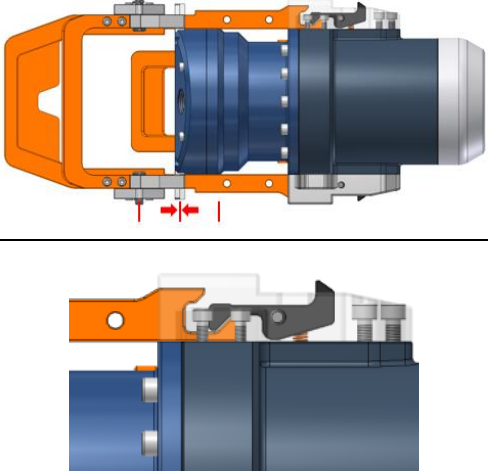
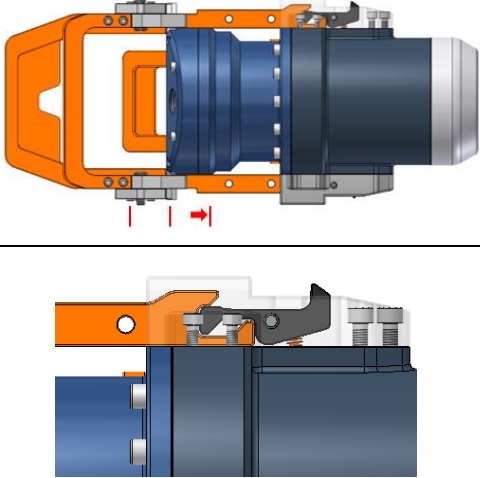
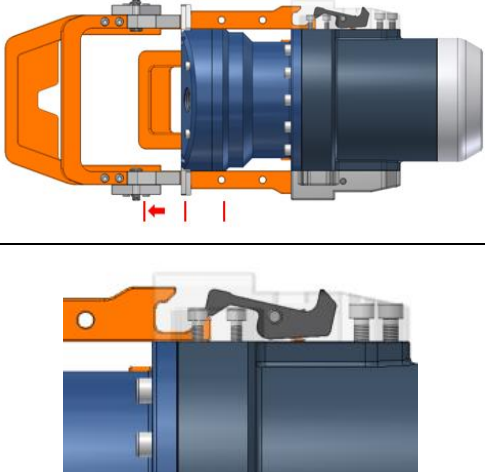

Figure 6: Locking system



Auto Latch:		
01	<p>Mid position. The latches are spring Loaded.</p> <p>When ELTT is being guided into the valve interface, the latches will auto lock the tool in the correct position</p>	
Latch Locked:		
02	<p>Handle is positioned all the way down.</p> <p>In order to lock the ELTT to the valve interface, the lock will complete full engagement of the system</p>	
Latch Open:		
03	<p>Handle positioned outwards</p>	

3.1.1.4. Position Feedback

ELTT is featured with two types of socket position feedback systems, one mechanically – directly coupled to the output shaft presenting the information through the gauge close to the ROV handle, and one electrically – providing feedback through the GUI. The position feedback presented in the GUI has a reset function making it possible to reset rounds and angle at any time.

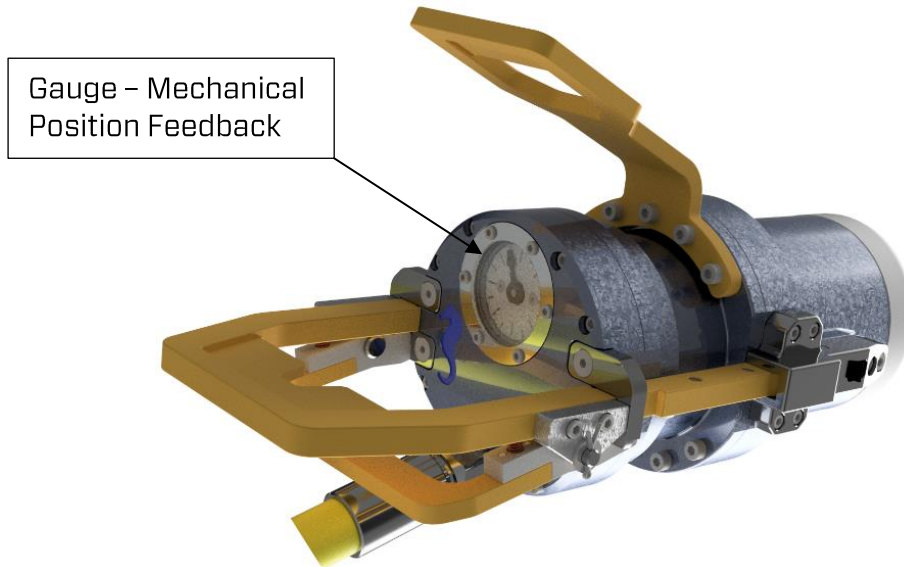

Figure 7: TT rear end with position feedback instrument



OPERATION AND MAINTENANCE MANUAL

3.1.1.5. Performance Data

Low Torque Mode	Max Output Torque	350 Nm
	Max Output speed	30 rpm
High Torque Mode	Max Output Torque	2700 Nm
	Max Output speed	6 Rpm
Max Output speed Low Torque Mode @350Nm		16 Rpm
Max Output speed High Torque Mode @2700Nm		3 Rpm



3.1.1.6. EI Power Can

The EPC is a separately installed power and control unit. The EI Power Can (EPC) is an atmospheric can filled with air, that converts supplied power 110 VAC +10/-15% to 230 VAC +10/-15%.

The EPC will normally be installed onto the ROV frame at a suitable location and is equipped with connectors for input power/ signal and Tool Output power and signal.

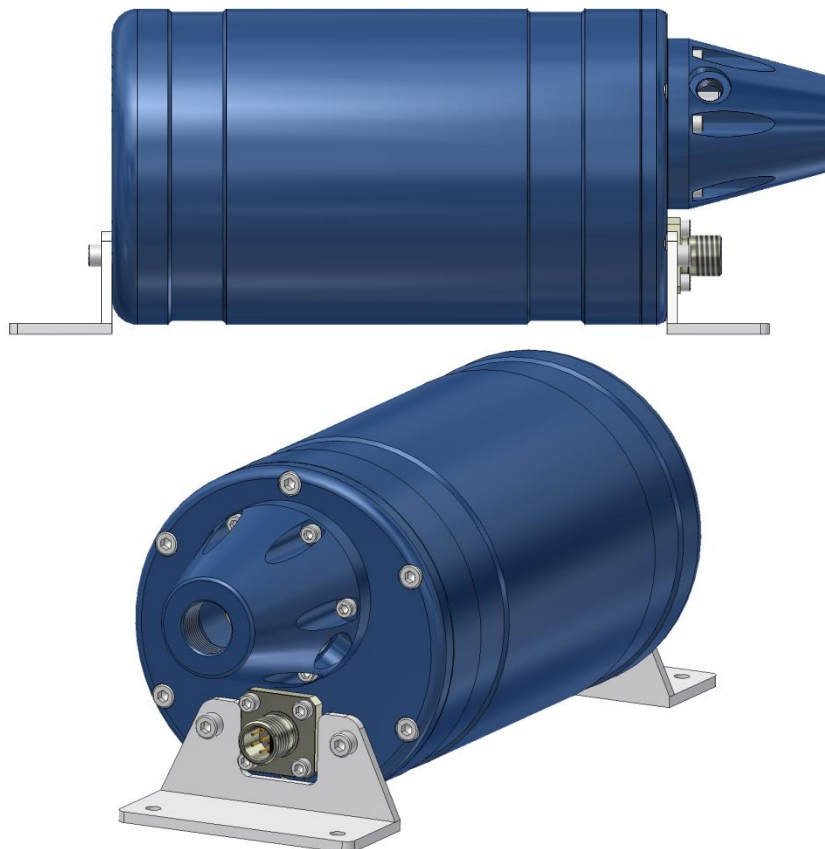

HIGH VOLTAGE: The EI Power Can operates on high voltage and has the potential to result in death or severe injury if handled incorrect. Qualified personnel should only use the equipment. The equipment contains no serviceable parts inside.

**OPERATION AND MAINTENANCE MANUAL****3.1.1.6.1. Technical Data EI Power Can***Table 7: Mechanical Data*

Description	Specifications
Depth rating	3000m

Table 8: Electrical Data

Description	Specifications
Input Voltage	110-230 VAC 50/60Hz or 160-320 VDC +10/-15%
Power Consumption, min	1,8 A @230VAC 0,95 @ 115VAC
Power Consumption, max	20 A

Table 9: Corrosion Control

Description	Specifications
Anodes	
NOTE: connect the control pod to ROV CP system If CP system is unavailable, install anodes on TT	

Table 10: Communication Data

Description	Specifications
RS232	Default *
* The default communication protocol is RS232 RS485 and Ethernet can be made available upon request	



3.1.1.6.2. Interface Description

Table 11: Electrical Interface

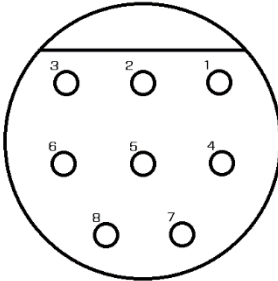
Interface	Interface Type
Burton connector 5507	2008 8 pin connector
	
Pin #	5506-2008-0004
1	110-230 VAC / 160-320 VDC
2	110-230VAC / 0VDC
3	Chassis
4	N.C.
5	RX RS232
6	TX RS232
7	N.C.
8	Com/GND

OPERATION AND MAINTENANCE MANUAL
3.2. BA8949, BB3151 - 2,7KNM TORQUE TOOL KIT W/INDUCTIVE CONNECTOR

NOTE: For description on the actual torque tool, see 3.1



Figure 8: BA8949 Torque Tool Kit with Inductive Coupler

The BA8949 kit consists of:

QTY	Art. No.:	Description
1	BA5247	BA5247 2,7kNm ELTT with 2kW Inductive Coupler
1	BB1745	Alu Box 240L incl. Foams Inductive Connector
1	BA6615	Class 3 Interface Socket
1	BA2951	Class 1 & 2 Interface Socket
1	600144-TD-0003	Operation and Maintenance Manual Electric Torque Tool Class 1 - 4
1	102862	Connector Subcon Dummy
1	102859	PC Charger Module
1	102858	Laptop HP Probook
1	102857	Computer Mouse
1	10181	9 Moxa Adapter DB9F to TB
1	10181	7 Pelicase 1495D
1	10106	7 Locking Sleeve Red incl. Snap Ring DLSA M
1	10068	7 Moxa UPort 1150I



Figure 9: BB3151

The BB3151 kit consists of:

QTY	Art. No.	Description
1	BB1743	Alu Box 240L incl. Foams
1	BB1043	Cable for PFC 2kW L=3,75m
1	BA9029	ROV Male 2kW Primary
1	BA7719	BL Power Supply 2kW
1	600128-TD-0013	Operation and Maintenance Manual 2KW Type C Subsea USB System
1	102768	Test Cable for USB Female
1	102766	Test Cable for USB Male

This kit contains the power connectors necessary to power the ELTT, either via inductive connector or EPC.



3.2.1. Technical Description for Electrical Torque Tool

See section 3.1.1

3.2.1.1. Technical Data

See section 3.1.1.1

3.2.1.2. Interface Description

See section 3.1.1.2

3.2.1.3. Locking System

See section 3.1.1.3

3.2.1.4. Position Feedback

See section 3.1.1.4

3.2.1.5. Performance Data

See section 3.1.1.5

3.2.2. Technical Description Inductive Coupler

The Inductive Coupler is a Blue Logic USB-C connector, modified to connect to the ELTT cable.

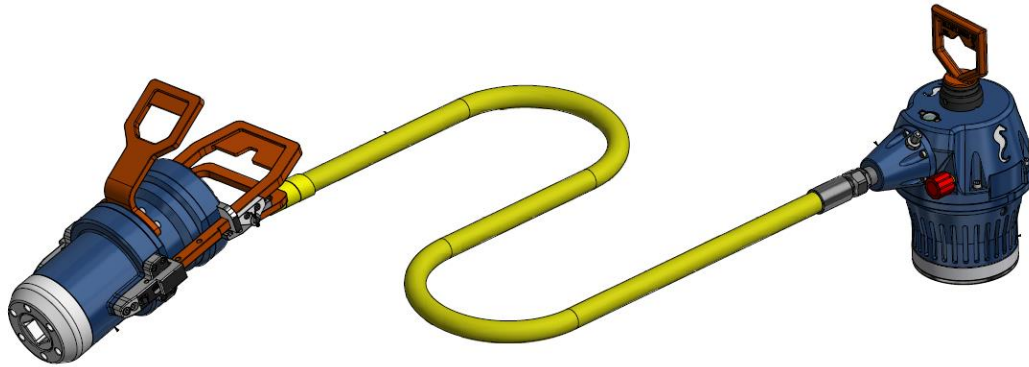

Figure 10: Electrical Torque Tool powered via IC



Figure 11: USB secondary side



Figure 12: USB primary side



CAUTION: The Inductive Coupler operates on high voltage, and has the potential to result in death or severe injury if handled incorrect. Qualified personnel should only use the equipment. The equipment contains no serviceable parts inside.



OPERATION AND MAINTENANCE MANUAL

3.2.2.1. Technical Data

Table 12: Mechanical Data

Description	Specifications
Depth rating	3000m

Table 13: USB Data

Description	Specifications
Power	2kW
SubConn Connector (secondary side)	See Table 16
SubConn Connector (primary side)	See /03/

Table 14: Corrosion Control

Description	Specifications
Anodes	
NOTE: connect the control pod to ROV CP system If CP system is unavailable, install anodes on IC	

OPERATION AND MAINTENANCE MANUAL
3.2.2.2. Interface Description Secondary Side Connector
Table 15: Mechanical Interface

Interface	Interface Type
Subsea secondary USB *	Type-C
*Max 30W for secondary side subcon 13 pin connector	

Table 16: Electrical Interface

Interface	Interface Type
SubConn connector	DBH13F 13 pin
Pin #	DBH13F
1	0V
2	Chassis
3	24VDC
4	N.C.
5	N.C.
6	N.C.
7	N.C.
8	TXn
9	TXp
10	RXn
11	RXp
12	N.C.
13	N.C.

**3.2.2.3. Interface Description ROV-PFC***Table 17: Electrical Interface*

Interface	Interface Type
SubConn connector	BCR2410M 10 pin
Pin #	
1	100-250VAC / 145-350VDC
2	100-250VAC / 0VDC
3	Chassis
4	RS232RX (input)
5	RS232TX (output)
6	RS232GND
7	TX_p
8	TX_n
9	RX_p
10	RX_n

OPERATION AND MAINTENANCE MANUAL

4. TOPSIDE CONTROL SOFTWARE

The control software for the ELTT is installed on a laptop that is operated from topside. The software controls the TT output, either in Nm, revolutions per minute or turn count. The software is also able to log/load operational data.

4.1. GUI

The GUI has two windows Main Window and Setup Window. The ELTT is operated from the Main Window, and displays tool feedback. It contains all operational data such as torque, speed, socket angle, torque graph, set limits and more.

The Setup Window is password protected, and enables the user to change parameters as well as selecting set limits.

Password can be made available on request to supplier

Operation Modes	Description
Manual	Normal start/ stop in selected direction, torque limit but no turn or angle limit
Multi turn	Running the tool a specified number of turns and/or angle



Figure 13: Main window



Figure 14: Setup Window

4.1.1. Main Window

Main window is split into eight sections named boards. The different boards contain all tool controls and information on tool feedback.

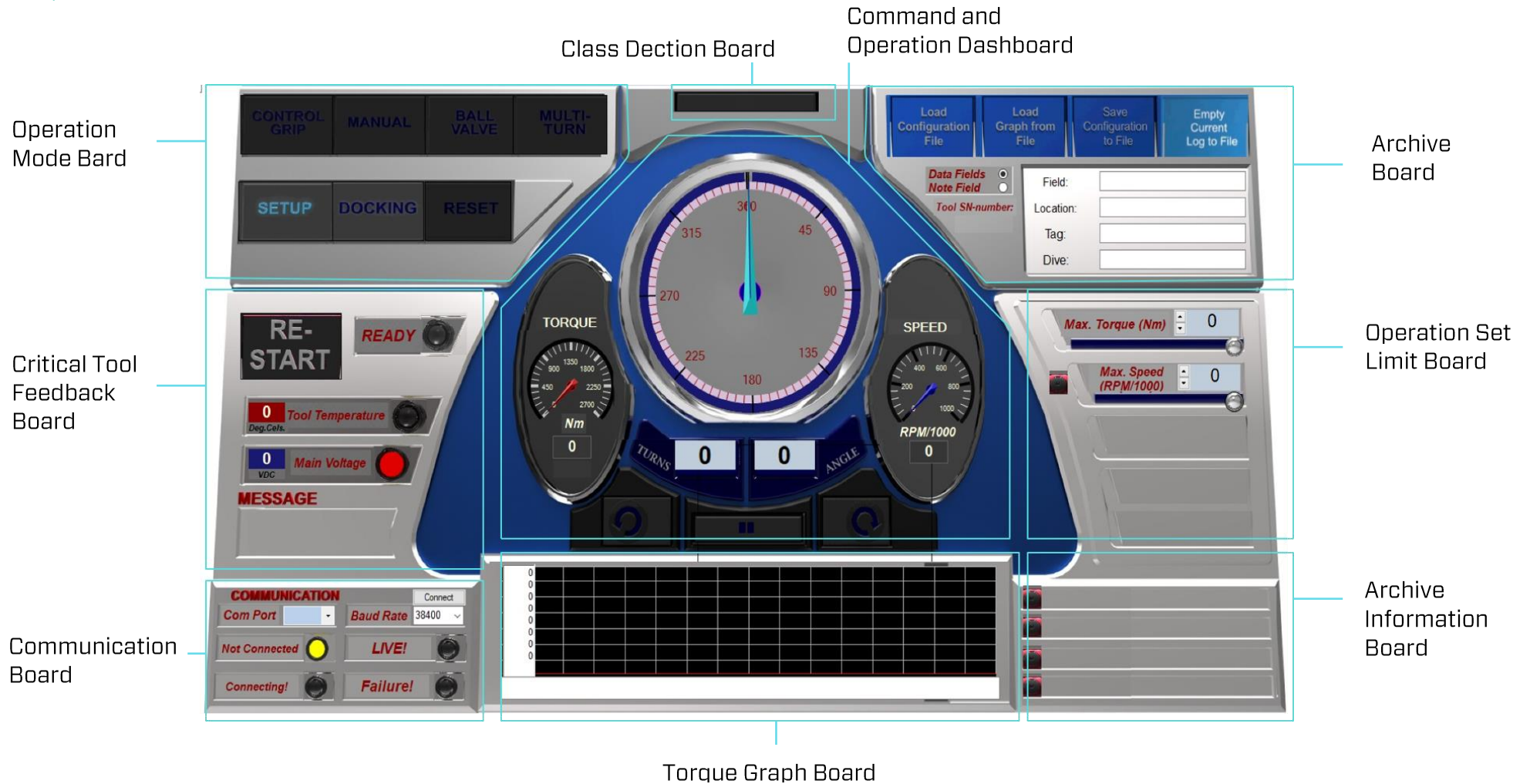





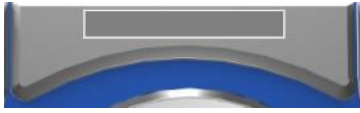
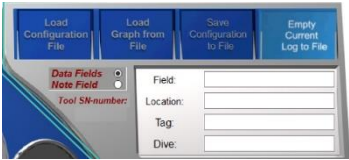

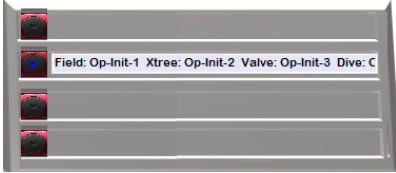

Figure 15: Main Window Overview



4.1.2. Main Window Information Boards

Board	Model	Description
Operation Mode Board		<p>The Operation Mode Board let the user select the different operational modes. In addition, the Setup Window can be entered here.</p> <p>Manual mode: Starts running when command button is clicked and stops when stop button is clicked.</p> <p>Multiturn mode: Rotates the tool towards a preset position. It will move and stops when target position is reached.</p>
Critical Tool Feedback Board		<p>Critical tool information is presented in this board.</p> <p>If self-protect function has shut down the tool, restarting the tool is done via this board.</p> <p>The Message window shows more detailed messages related to instrument lamps and status. Messages are:</p> <ul style="list-style-type: none"> - Description of alarms/warnings. - Status indication (e.g. Initializing or Operating).
Communication Board		<p>Presents communication information</p>
Command and Operation Dashboard		<p>This board holds the command buttons on operating the tool and the operational feedback.</p>



<p>Class detection board</p>		<p>This field will default show the auto detected Iso Class output pipe. This field will default show the auto detected Iso Class output pipe (governed by if the pipe is connected to stage 2 or 3 in the gear)</p> <p>In special cases where special designed output pipes are used, the field can be manually edited, see section 7.3.2</p>
<p>Archiving Board</p>		<p>Report Board holds the Archive and filing functions.</p>
<p>Operation Set Limit Board</p>		<p>Holds the operational set limits used when running the tool.</p>
<p>Graph archive Information Board</p>		<p>The Graph Archive Information Board presents data information on the loaded graph file. Left button/Indicator shows/hides selected graph.</p>
<p>Unit setting</p>		<p>By default, position unit appears as turns and degrees.</p> <p>*** Work In Progress, not yet functional ***</p> <p>By pressing the unit button, a selection window gives the possibility to change monitored position units.</p>



4.1.3. Setup Window

Setup window is divided into four sections holding the different set limits, limiting the operational freedom found in the Main Window. The set limits can have a huge impact on ELTT performance; a password has been applied in order to change values.

Both the Performance Config and Failsafe Configurations are password protected, with two different passwords.

Passwords can be made available on request to supplier.

Setup window also shows actuator data that are loaded from the actuator during connection.

An additional “Advanced settings” window may be opened containing Alarm/warning settings and limits.





The screenshot shows the 'ADVANCED SETTINGS' window for 'CLASS 1 AND 2' and 'CLASS 3 AND 4'. The left panel contains performance and motor data, while the right panel contains functional and failsafe configurations. Callouts point to specific sections:

- Advanced settings (typical factory settings only):** Points to the 'ADVANCED SETTINGS' header.
- Performance config:** Points to the speed, torque, and power settings.
- Operation times and motor data (read only):** Points to the live time, operation time, and motor specifications.
- Archiving setup:** Points to the 'Select Report File Folders' section.
- Functional and Failsafe configurations:** Points to the 'FUNCTIONAL CONFIGURATIONS' and 'FAIL SAFE CONFIGURATIONS' sections.
- Class and sensor factors:** Points to the 'Class detect value' and 'Main Volt offset' settings.

Figure 16: Setup Window Overview



4.1.4. Setup Window Sections

Section	Mode	Description
<p>Performance Config.</p>		<p>This board holds all absolute max limits towards socket output values (Torque speed).</p> <p>Acceleration/deceleration settings can also be accessed here</p> <p>Large number = fast speed change.</p> <p>Low number = slow speed change</p> <p>Changes require password (Ref. section 3.4.1.3)</p>
<p>Operation times and Motor data (Read only)</p>		<p>Times -Total live time;</p> <p>Complete time when tool has been connected are shown</p> <p>Total operation time; Shows accumulated time when tool have been performing operation</p>



Advanced settings

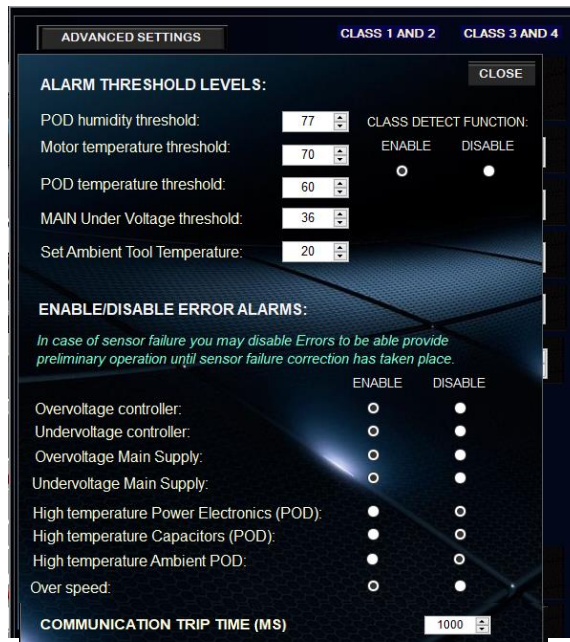

Advanced settings are factory settings for alarms.

Alarm threshold levels

These are levels that when reached will cause errors that shuts down operation to protect the system.

Class detect function

Here you can lock class and disable the class Detect function. If disabled class sensing will not occur but chosen class in “select class” will automatically be set.

Warning: be sure that correct socket is installed, otherwise operation failure will occur and possible damage may occur.

Enable/Disable error alarms

Alarms may be disabled to prevent shutdown in case of sensor failure.

Warning: When any alarms are disabled the system protection level is reduced. Thorough consideration and manufacturer approval should be performed before any alarms are disabled.

Communication trip time:

This setting defines how long Time Torque tool will operate without receiving any data from GUI. Default; if Torque tool do not receive any data for 1 second (1000 ms) operation will shut down.

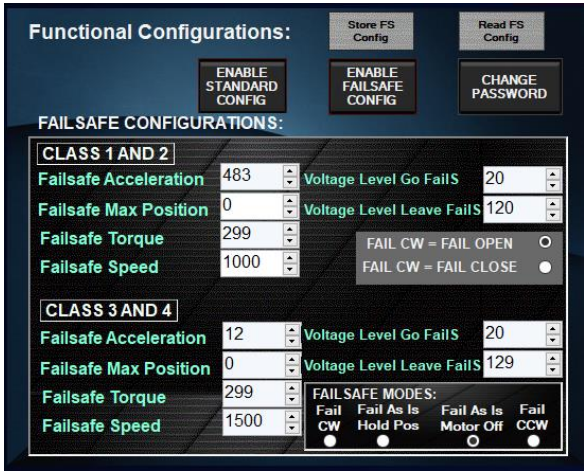
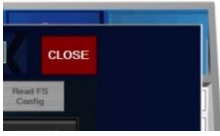

		<p>If communication is very slow this value may be increased to avoid trip, or some critical operations may require a lower value for faster shut down.</p>
<p>Functional and Failsafe Configurations</p>		<p>Standard configuration and failsafe configuration are password protected with unique passwords (Ref. section 3.4.1.3)</p> <p>Calibrate standard configuration Gives the user access to change performance limits.</p> <p>Enable failsafe configuration Gives the user access to failsafe configuration</p> <p>Note: be sure of the rotating direction of failsafe; open or close</p>
<p>Checkout and Confirmations</p>		<p>In order to exit Setup Window click the close button</p> <p>The configuration is auto saved when Setup Page is closed</p>



4.1.5. Operational Modes

The different operational modes are pre fixed operation programs designed to suit ELTT operations. By being able to select between several modes containing different safety and limit features, the operation can be conducted with high safety.

Two modes are available: *Manual* and *Multi Turn*

Manual:

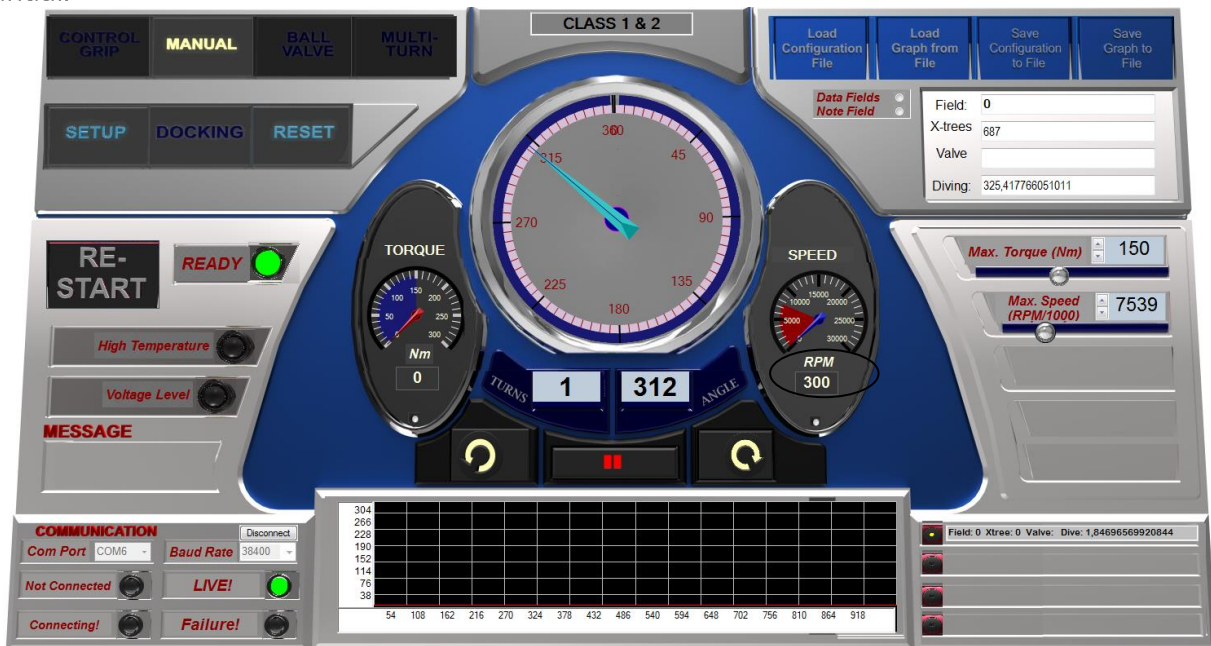

Figure 17: GUI Manual Mode

In Manual mode the ELTT will start continuously running according to selected speed. If required torque is higher than selected torque, actual speed will be lower than selected speed. Tool output will be stopped when stop button is engaged, or selected torque limit prevents running. Target position or number of rotations cannot be set in this mode.



Multi Turn:



In Multi Turn mode the operator can select relative number of turns and rotational degrees the ELTT shall run before it stops. This mode is available first when reset are activated and all positions are set to zero. When in Multi Turn Mode a section in Operation Set Limit Board will appear where to set target position before operation. Set position is relative according to present position.

Ex.: If 2 turns and 126 degrees are set, Torque tool will rotate to the given distance in selected direction.

When target position is reached a new operation will rotate the output shaft the same distance in addition.

E.g.: if 1 turn and 180 degrees are set, and the Torque Tool has reached target position. If a new operation activates with the same settings target position will be 3 turns and 0 degrees. Alternatively, if a new operation in opposite direction is activated target position will be 0 turns and 0 degrees. (See point 3 below).

Speed setting and torque limit may be change during operation.

The Following functions are available in this mode:

1. Stop:
During operation, it is possible to stop the rotation by pressing the stop button. If target position is not reached the rest of the operation is excluded. Pressing new operation will start a new distance according to selected rotational distance.



2. Freeze:

If freeze is selected operation will stop temporary. A blinking message will indicate that temporary stop is activated, and the freeze button text will change to “unfreeze”. Selecting the unfreeze button will continue the operation until target position is reached.

3. See target absolute position.

When relative move is set, the absolute target position can be shown by holding the mouse pointer over the start buttons. (Either clockwise or counterclockwise). Target position is shown in the miniature Turns and angle windows.



4. Change target position during operation.

If new target position is changed during operation, output shaft will start to rotate towards new target automatically. If actual position is beyond new target position rotation, will immediately change direction and move towards new target position.



5. AUXILIARY EQUIPMENT

5.1. EQUIPMENT MATRIX

Action	LOGISTICS	MOBILIZATION	DE-MOBILIZATION	PRE DIVE PREP.	POST DIVE PREP.	OPERATION	MAINTENANCE
Typical Tools. Allen Keys, Wrench and sockets.		X		X	X	X	X
PPE	X	X	X	X	X	X	X
Calibration jig		X					X



6. MOBILISATION/DE-MOBILISATION

6.1. ONSHORE PREPARATIONS

Prior to shipping offshore a mobilization/ verification should be performed. All functions should be tested and verified. The following checklist should be used as a guideline for activities to be performed prior to offshore mobilization

No.	Description	Check/Verified
01	Inspect Tool (ELTT) for visual damage or unusual wear and tear	
02	Inspect EPC and/or IC for visual damage or unusual wear and tear. Special attention should be focused on its connectors.	
03	Inspect Umbilical/Cable for visual damage or unusual wear and tear	
04	Inspect that the ISO key is secure and fastened.	
05	Assemble the ELTT system and connect to power. Make sure that umbilical has the slack necessary to operate the ELTT	
06	Verify that the ELTT functions can be operated when connected.	
07	Verify that the torque is accurate by use of a calibration jig.	
08	Check oil level, there should be 1 bar overpressure. Refill from check valve on top of the TT. Let ELTT stand on the floor with the position feedback glass as the highest point. There should be minimal air bubbles visible inside the glass. Squeeze umbilical to view impact on air bubbles.	
09	Disassemble ELTT and store it in transport box	
10	Verify correct packing and documentation in the transport box. The transport box should include as a minimum Electrical Torque Tool Operation and Maintenance Manual	

**6.2. MOBILISATION PROCEDURE***Table 18: Mobilization Procedure*

Item	Procedure
1	Check the condition of the transport box. Repair any damage or replace if necessary.
2	Check all items to be present according to the inventory list.
3	If any, check and follow the check-out procedure before delivering the tool for shipping.

6.3. DE-MOBILISATION PROCEDURE*Table 19: De-mobilization Procedure*

Item	Procedure
1	Perform preventive maintenance according to /05/
2	Check the condition of the transport box. Repair any damage or replace if necessary
3	Check all items to be present according to the inventory list.
4	Fill in EFR if necessary. (To be stored in transport box.)
5	Storage according to chapter 9.3



7. OPERATION

7.1. TOPSIDE OPERATION

When performing operation above water do not run tool on full load for prolonged periods.

Observe the Graphical User Interface for temperature warnings.

Consider water-cooling if operation is expected to take time.

Consider ambient temperature.

7.2. OFFSHORE PREPARATIONS

7.2.1. Pre Dive Check

Prior to dive, the Electrical Torque Tool System should be inspected and function tested

No	Description	Check/Verified
01	Inspect Tool (ELTT) for visual damage or unusual wear and tear	
02	Inspect Power Can (EPC) or (PFC (part of Subsea-USB system)) for visual damage or unusual wear and tear	
03	Only Subsea-USB: Inspect Subsea-USB system with special attention to coil surface.	
04	Only Subsea-USB: Verify Subsea-USB connectors mate completely	
05	Inspect Umbilical/Cable for visual damage or unusual wear and tear	
06	Inspect that the ISO key is secure and fastened.	
07	Verify that the ELTT is connected to power	
08	Verify that the ELTT functions can be operated when connected.	
09	Verify torque in calibration jig if available	
10	Verify and test locking mechanism	

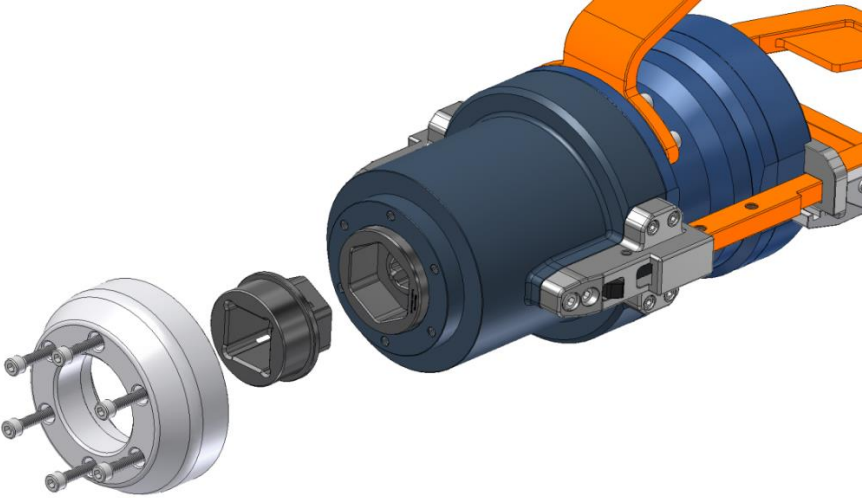

7.2.2. Changing the ISO Key

No.	Description	Check/Verified
01	 <p>Remove the six M8x35 Socked Head bolts located at ELTT nose</p>	
02	Remove POM nose	
03	Switch socket to the one desired. Clean socket holder thoroughly if dirty.	
04	Install POM nose and bolts. Note: Use Aqua lube and thread lock on bolts before mounting	



7.3. PRE-DIVE OPERATION STARTUP

After communication has been established, the following must be done in order to start an ELTT operation:

- Check set-up settings
- Detect interface socket
- Select operation mode
- Add archiving information

7.3.1. Check Setup Settings

When defining setup settings the following checklist should be followed, though not limited to:

No.	Description
01	Max ELTT power consumption set according to host power supply
02	ELTT max engine rpm is set according to highest suitable operational socket rpm
03	Max output torque is set according to operation
04	Max output torque, Ball Valve mode, set according to operation
05	Docking torque set according to operation
06	CW acceleration set
07	CCW acceleration set
08	Break torque end position
09	Seating Torque start position
10	Arrange archiving file structure
11	Verify Failsafe Config

7.3.2. Torque Class Detection

By recognizing socket interface class, the tool will automatically select between Low and High Torque mode.

No.	Description	Figure
01	Push Class identification button to detect class. A small motion starts for sensing output socket type.	
02	Confirm automatic or manual class detection	
03	If manual mode is selected chose class, consider warnings and confirm with OK	
04	When selected class is detected, define configuration and limits respectively. Class is shown in top window	
05	Startup is completed and Torque tool is ready for operation	
06	If socket class is not detected, all operations are disabled. (See trouble shooting section; “Not able to Class Detect”)	
07	To change class at a later stage, perform following instructions: Turn off current selected mode. Now the Class Identification button are blinking weakly. Push the button and process class detection as described above	



7.3.3. Add Archiving Information

In order to edit Tag information select “Data Fields”.

Click in the fields and fill in the texts

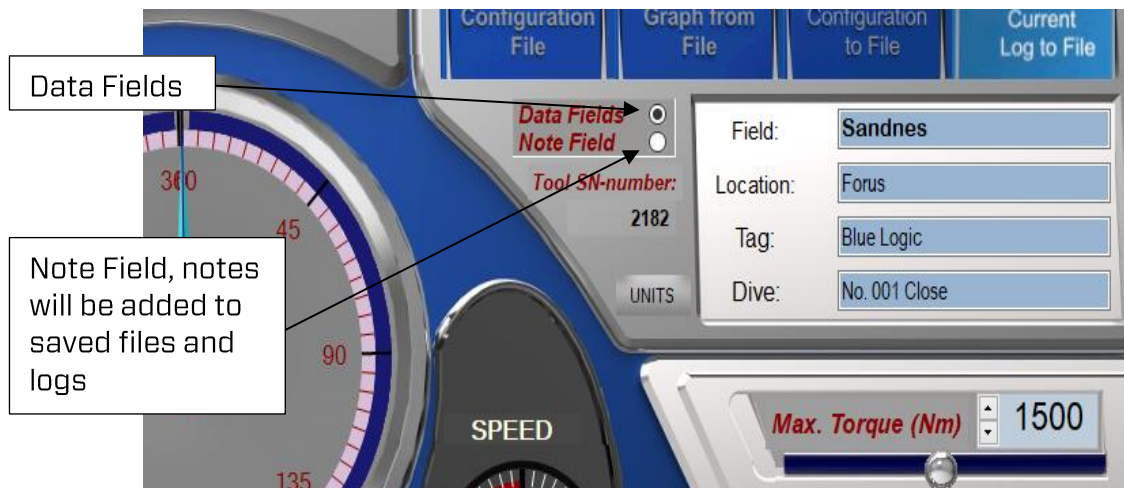

The following operations data may be typed in or imported by loading configuration file (See section 7.9.1).

Pressing the button for Note Field a field for notes appear. Here the operator can include notes or free text related to the operation. This text will be included in the Configuration file together with operational data, date and time. (See section 7.9.1).

**7.4. SUBSEA OPERATION**

No.	Description	Check/Verified
1	Only Subsea-USB: Inspect the primary/secondary to be mated by ROV visually. Verify that mating surfaces are clean	
2	Only Subsea-USB: By use of the ROV manipulator gently mate the male and female (primary/secondary) connectors.	
3	Only Subsea-USB: Verify that the connectors are fully mated and that cables are undamaged	
4	Start ELTT Software and communication.	
5	Verify ELTT Engage Latch Handle to be positioned in Mid position.	
6	Adjust max torque value according to valve to be operated.	
7	Dock ELTT into selected location by use of D-Handle. If ELTT does not interface valve bucket due to un-alignment of valve stem and interface socket, start Docking Mode in GUI.	
8	Change grip to Engage Latch Handle. In order to complete full engagement on to valve bucket, set Engage Latch Handle in Latch Locked position.	
9	Operate Torque Tool in order to complete valve operation. Note: If comments to valve operation gains additional track information. Add comments to note board.	
10	Stop Torque Logging	
11	Release Torque Tool from valve bucket.	



7.5. POST DIVE CHECK

No.	Description	Check/Verified
01	Recover ELTT equipment to deck.	
02	Perform a visual inspection Seals Seal areas ROV Handle Flex Joint Hoses and piping Fittings Surface treatment	
03	Flush all equipment thoroughly with fresh water	
04	Subsea-USB: Connect system and perform a full systems check	
05	Dry off equipment and apply protective oil, WD40 or similar, prior to storage	



7.6. HOOK-UP AND COMMUNICATION

The ELTT System is easily installed to its host, connect the Torque Tool to EPC or Inductive Connector. When the program is started communication must be established and verified (see table below).

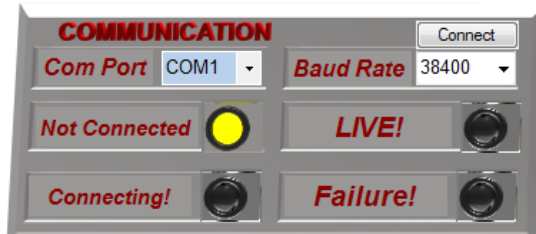

Figure 18: Communication Board

No.	Description
01	Select com port
02	Press Connect
03	Connecting!: Yellow – Connection in progress. LIVE: Green – communication with Torque tool established. Failure!: Red – Communication with Torque Tool failed. (See trouble shooting section; “Communication problems”).



7.7. ELTT OPERATION

7.7.1. Operational Controls

This section describes general operation controls for start, stop and adjustments:

	<p>The right and left arrows will start rotation in direction as indicated (clockwise or counterclockwise). If the symbol is steady lit the ELTT is ready to operate.</p>
	<p>If any symbols are dark, the ELTT is unable to perform that operation. Typical If the system is not ready or no mode has been selected.</p>
	<p>Only valid in speed mode. Symbol light rolling. This occurs when button is clicked (<u>NOT double clicked</u>) and left mouse button is held down. Output shaft rotates clockwise according to torque and speed settings and stops when left mouse button is released.</p>
	<p>Output shaft rotates clockwise according to torque and speed settings, even if the left mouse button is released. (To stop rotation stop button needs to be pressed, or target position are achieved.)</p>
	<p>If stop button is dark the operation is not valid :</p> <ul style="list-style-type: none"> - No rotation started - No mode set - System not ready
	<p>The stop button light is steady red when output shaft rotates. Pressing stop button will stop the rotation.</p> <p>To activate soft stop according to the set deceleration, press stop button once (do not double click). Stop button will start blinking until rotation has completely stopped.</p> <p>To activate quick stop, double click the button</p>



7.7.2. Unit settings

Two units are selectable:

1. Turns and degrees.
2. Turns with decimals *** Work In Progress, not yet functional ***

The position instrument and angle number reports position as an absolute protractor i.e. that during a counter clockwise operation degrees goes from 359 – 0. This may be a bit confusing since if you will go 45 degrees from 0 counter clockwise, the instrument and angle will show - 270 degrees.

Default unit are “Increase Degrees only clockwise” The position instrument shows the outputs sockets absolute position. If distance to run are 45 degrees counterclockwise from zero, the needle will stop at 270 degrees. To achieve the same output socket rotational position by running clockwise the distance must be 270 degrees.

If you select “Increase degrees both dir. From Zero” the instrument will change scale when passing 0. This means that Instrument and angle number will show correct proceed distance from 0 in both directions. Counterclockwise side of zero will appear with (-) sign. Valid in both units. Here set angle value will always respond with angle position value and instrument value.





7.7.3. Adjustment Operations

In every mode and before or during operation, Torque limit and speed can be adjusted in the Operation Set Limit Board or Command and Operation Dashboard



Adjustment can be performed by pressing and dragging the slider handles in the Operation Set Limit Board, or by clicking the one-step vice selector. Values can also be typed directly in the Operation Set Limit Board.

Maximum values are limited by the absolute max values set in Setup Window (see section 4.1.4). If a higher value is typed, the value will change to predefined absolute max value (for safety reasons). The Slider bar range will always be adjusted according to the predefined absolute maximum value in the setup.



7.7.4. Torque and Speed Monitoring (Meters)

Instrument range:

Range for instruments is defined by absolute max values set in the setup window.

Marked area:

Marked area in instrument are defined by selected max value set in the Operation Set Limit Board (Section 3.4.1.2).



Meter needle:

Meter Needle show measured instrument value. (Also given in text below instrument).



Torque limit verified:

Torque limit shown in blue below the instrument are Torque limit load from control POD (safety control). Shall be equal to Torque limit set in Operation Set Limit Board

7.7.5. Reset Socket Position

Pressing reset will set actual output socket position to zero.

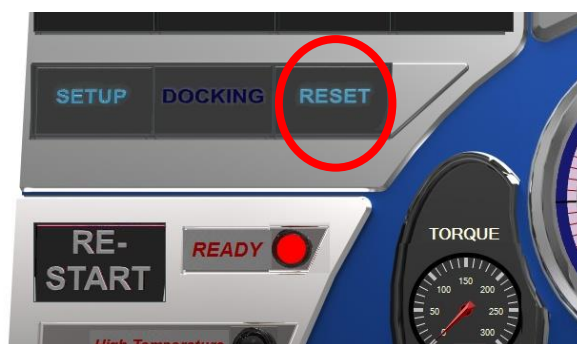



7.7.6. Diagnostics and Restart

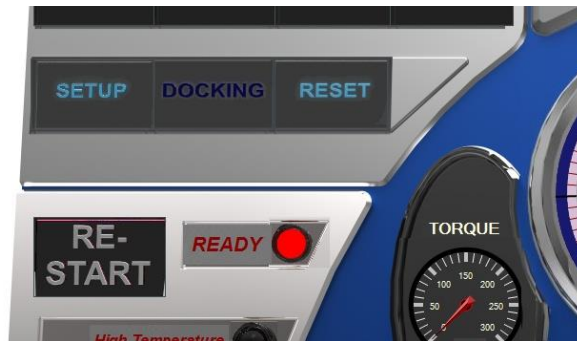

ELTT System Diagnostics contain continuously monitoring of the following parameters:

- El-Pod temperature
- Transistor cooling block temperature
- Actuator temperature
- Main Supply voltage
- Motor current
- Performed Torque
- Motor position
- Actuator output shaft position

Warnings according to the above list will change the “Health” lamp to yellow, and specified details will occur in the “MESSAGE” window.

Error will change the “Health window” to red and operation is shut down. Exception is if detected error is disabled. (see section 3.7.7)

Specified details will occur in “MESSAGE” window.

If high temperature is detected, reset will not be possible until acceptable temperature is reached again.



7.7.7. Error Shut Down Override Function

If sensor failure occurs, operation may shut down and the tool will be impossible to operate.

If it is obvious that sensor value is a result of sensor failure, shut down function can be overridden by disabling respective sensor in Setup; advanced settings (Section 3.1.4; Advanced Settings).

If error is disabled in Setup, and confirmed by operator during startup, error message will still occur, but operation will not be shut down.

In addition to the error message in the message window a blinking message will appear below the message window to notify the operator that error shut down is overridden. If one or more errors are disabled at startup and the operator decide to have all errors enabled select “Enable all errors” and continue without entering setup.

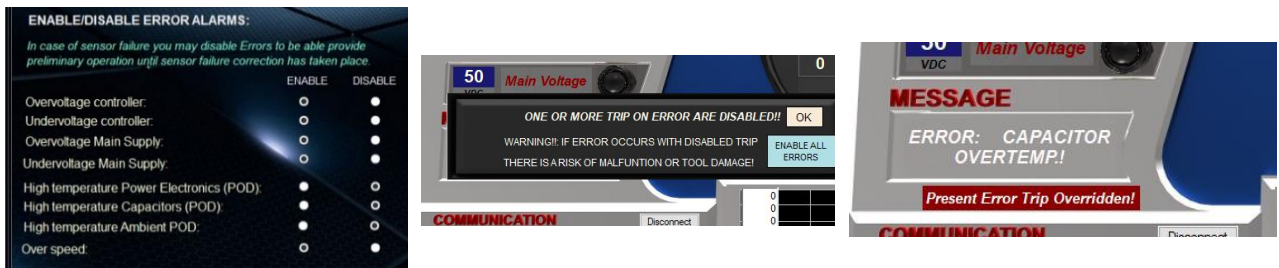

Pressing the restart button will reset the error and reactivate the tool. The ready lamp will change from red to green. If the error reset is not possible as a result of hazardous failure, the ready lamp will stay red and error message will remain. (See section 3.7.6).

OPERATION AND MAINTENANCE MANUAL

7.8. XLS TORQUE REPORTING

The logging function is divided into 3 levels:

- 1) Tool Level: Everything done with the tool (automatic)
- 2) Log Level: one file for every active change in “Archiving Information”
- 3) Start Stop Level: every time you push “Save Graph to File” button.

All of the 3 files can be printed to a report in .xls file

7.8.1. Generate Operation Report (PDF)

Use the following sequence to generate a PDF rapport:

<p>1</p>	<p>Click the “Empty current log to file” in the Archive Board (see Figure 15)</p>	
<p>2</p>	<p>Enter data in the Data Fields</p>	
<p>3</p>	<p>After operation: Click the “Empty current log to file” in the Archive Board (see Figure 15)</p>	



4 Open the following Excel file:
E:\Torquetool log files\Torque Import_rev3.xlsm

5 Click the “Load Data” button

6 Open the following Excel file:
E:\Torquetool log files\” Choose desired date folder” \” Choose desired .xlsm rapport”

7 Click the “Save PDF” button
The PDF is saved in the relevant

The screenshots show the 'TORQUE TOOL REPORT' interface. The top section includes report metadata like 'Date of Report: 02.03.2017 16:08:00'. Below this is a 'Configuration Values' table with columns for 'Min config. Value', 'Value', 'Operational Value', and 'Max'. The table lists various parameters such as 'Absolute Max. Power (MVA)', 'Absolute Max. Torque (kNm)', and 'Max. Torque at Full Power (kNm)'. A 'Torque Signature Torque and Speed' chart is displayed, plotting Torque (Nm) and Speed (RPM x 1000) against Absolute Position. On the right side, there are several buttons: 'Load Data', 'Save XLSX', 'Print Report', 'Save PDF', and 'Copy Chart to Report'. In the first screenshot, the 'Load Data' button is highlighted with a red box. In the second screenshot, the 'Save PDF' button is highlighted with a red box. A 'Report er ferdig' (Report finished) message is visible at the top right of the interface.



7.8.2. Save or Print Report



In order to print the entire report, the user must select all the tab at the same time:



First select the “Report” tab hold down the “Shift” key on the keyboard and click the “Data1” Tab, now all tabs are white and will be printed or saved to PDF. When all tabs are selected, a change in the spread sheet cells will make a change to the call of all the tabs at the same time. **It is important that you unselect the sheets after print or Save, hold shift and click on “Report” tab.**

7.8.3. Load Graph from File

It is possible to load a previous graph to the display:

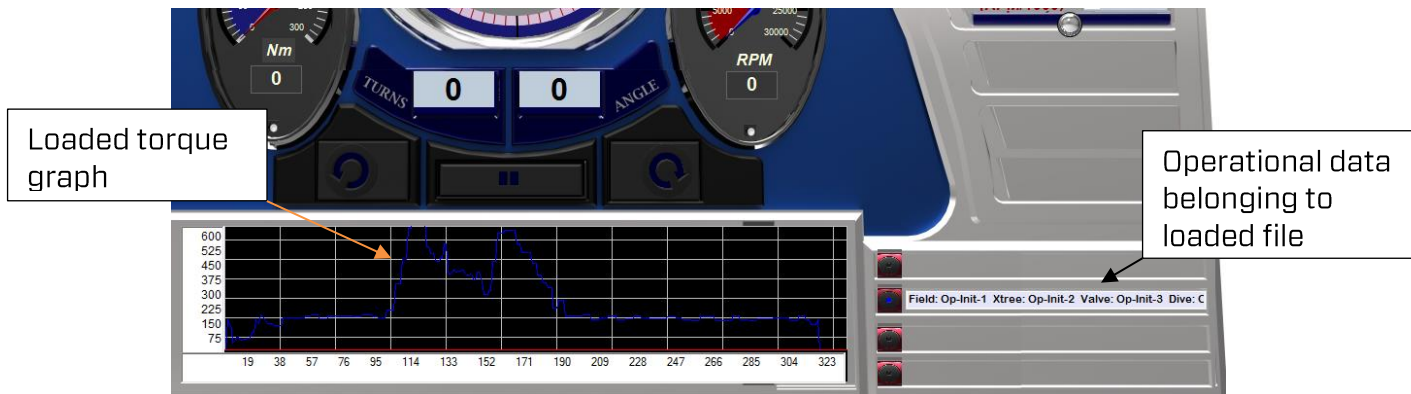

The loaded graph will appear in the graph window and torque-position ranges will be adjusted accordingly. Operational data for the loaded graph appears in the side window.



7.8.4. Report Front Page

All operational configuration parameter will be included in the top section:

TORQUE TOOL REPORT

Date of Report: **02.03.2017 16:08:08**

Field: **Sandnes**

Location: **Forus**

Tag #: **Blue Logic**

Operation#: No. 001 Close

Configuration Values				
Max config. Values	Class 1 & 2	Class 3 & 4	Operational Values	Values
Absolute Max. Power (Watts):	12000	0	Torque Limit GUI (Nm)	102
Absolute Max Speed (RPM/10):	12000	6000	Running Speed in GUI (RPM)	2293
Absolute Max Torque (Nm):	450	2500	Target number of Turns	0
Max Speed Ball Valve (RPM/10):	777	888	Target number of Degrees	0
Docking Torque (Nm):	270	1000	Operating torque Class:	Spare
Acceleration (Rev/Sec ²):		1500		
Deceleration (Rev/Sec ²):		10000		
Seating Torque start position (%):	1000			
Breakout Torque end position (%):	1000			

The max configuration values should be the damage torque and the Operational values should be the running torque of the task at hand.



7.8.5. Chart

The plot of a torque job is presented in a 2D chart. Both Torque (Blue) and Speed (Red) are plotted.

The speed value is plotted in the same value as input on the tool RPM multiplied with 1000. E.g. a plotted speed of 2500 is equal to an RPM of 2.5.

On the X-Axis the Start position and stop position is plotted as a value of 3663 degrees divided by 360= 10,18 revolutions, or 10 revolutions and 63 degrees.

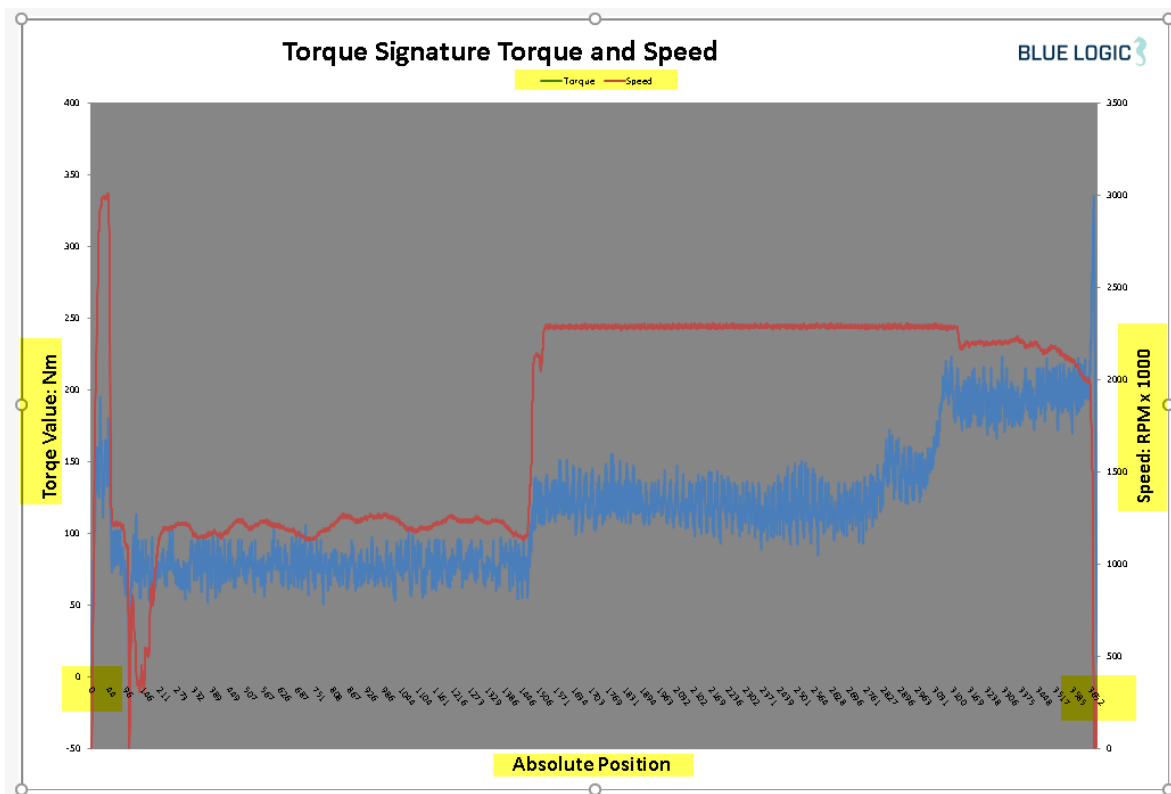

7.8.6. Automatic Filename Calculation

Year 2017
Month 3
Day 2
Hour 16
Minute 8
Second 8

Filename: **2017_3_2_16_8_8_Sandnes_Forus_Blue Logic_No.001 Close**

Year, Month, Day, Hrs, Minute, and second + the for location parameter.



7.8.7. Change Log

All key strokes by the tool operator is logged. The Tool position, time stamp, torque value, speed and system action, and manual notes will be included in the change/event log.

BLUE LOGIC

TORQUE TOOL REPORT

Date of Report: **02.03.2017 16:08:08**
 Field: **Sandnes**
 Location: **Forus**
 Tag #: **Blue Logic**
 Operation#: **No. 001 Close**

Change Log				
Absolute Pos	Time Stamp	Torque	Speed	Action
0	02.03.2017 15:56:01	0	0	Sys_Class manual selected
0	02.03.2017 15:56:05	0	0	Sys_Manual Mode Set
0	02.03.2017 15:56:07	0	0	Sys_Start Clockwise
0	02.03.2017 15:56:07	0	0	Sys_Start Clockwise
0	02.03.2017 15:56:07	0	0	Sys_Start Clockwise
105	02.03.2017 15:56:19	69	1103	Sys_Stop
108	02.03.2017 16:01:38	0	0	Sys_Start Clockwise
108	02.03.2017 16:01:38	13	4	Sys_Start Clockwise
133	02.03.2017 16:01:46	66	368	Sys_Start Clockwise
133	02.03.2017 16:01:46	66	368	Sys_Start Clockwise
134	02.03.2017 16:01:46	67	364	Sys_Start Clockwise
134	02.03.2017 16:01:46	67	364	Sys_Start Clockwise
134	02.03.2017 16:01:46	75	366	Sys_Start Clockwise
134	02.03.2017 16:01:46	75	366	Sys_Start Clockwise
3664	02.03.2017 16:07:53	90	39	Sys_Stop

All reports will also have a time stamp of when they were printed to the csv file.



OPERATION AND MAINTENANCE MANUAL

7.9. PREDEFINED OPERATIONS

It is possible to predefine an operation by manipulating certain files.

7.9.1. Save to/load from Files

Configurations, torque-position graphs can be loaded from file or saved to new files. Filename will contain operational data. File folder can be defined in the setup window. Otherwise, a folder will automatically be established on the C-drive, with relevant subfolders.

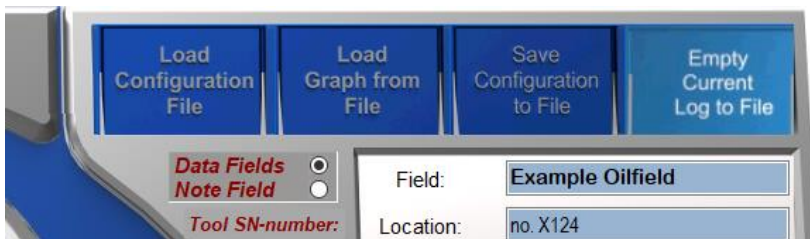

Select «Load Configuration File» to load

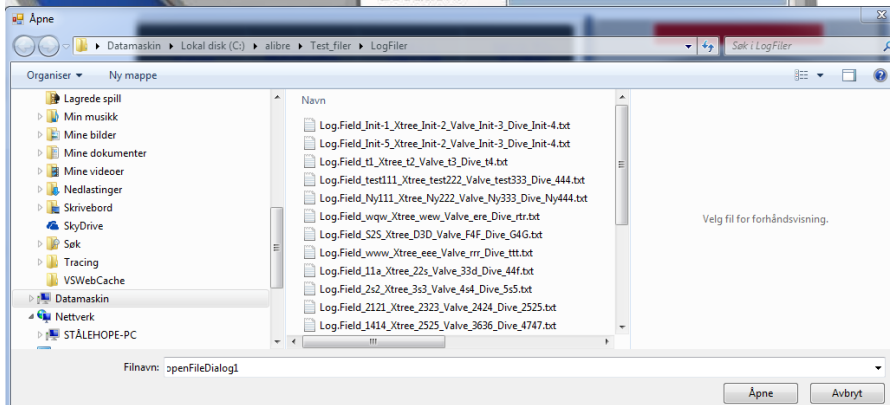

Select desired files for loading

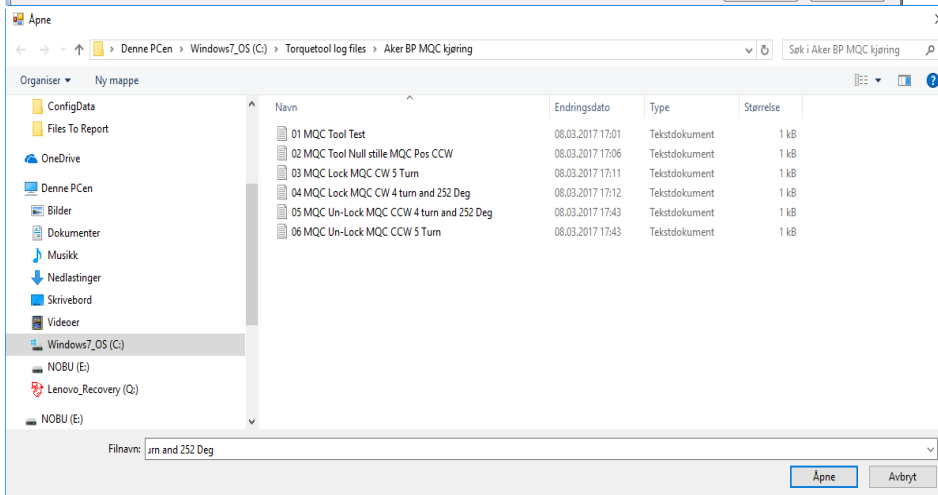

Select desired files for loading



Predefined or default folder is shown in the open window. Since operational data is part of the filename, it should be easy to select the relevant file. When the file is selected, press “Open”. The configuration is imported and data in the setup window will be updated.

It is important to verify that the intended configuration file is correct loaded since configuration files contain limits. These limits can have a huge impact on ELTT performance.

Press Setup and check configuration data.

All files saved in txt format.

When each operation is completed a graph-file are automatically saved to a folder named the current date, in E:\Graphfiles\.

(E.g. E:\Graphfiles\2019.3.26\ReportLog.Field_Location_Tag_dive_3.txt)

7.9.2. Preparation of Configuration Files for Each Activity

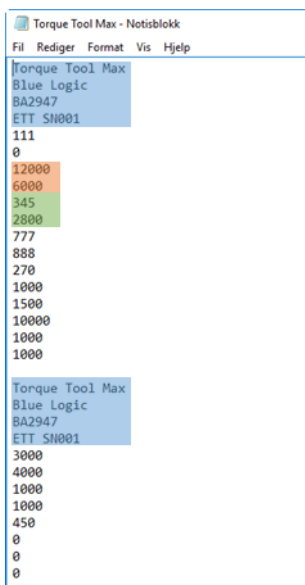

First 4 lines of the torque report (in blue)

Class 1-2 Max speed (in orange)

Class 3-4 Max speed (in orange)

Class 1-2 Max Torque (in green)

Class 3-4 Max Torque (in green)

Note: the colors do not appear in notepad

Open in Note pad to adjust.

In order to prepare the ROV operation it can be valuable to prepare separate files for every torque operation. That way it is much easier to change wording on the torque graph reporting during the offshore campaign.

See example below:

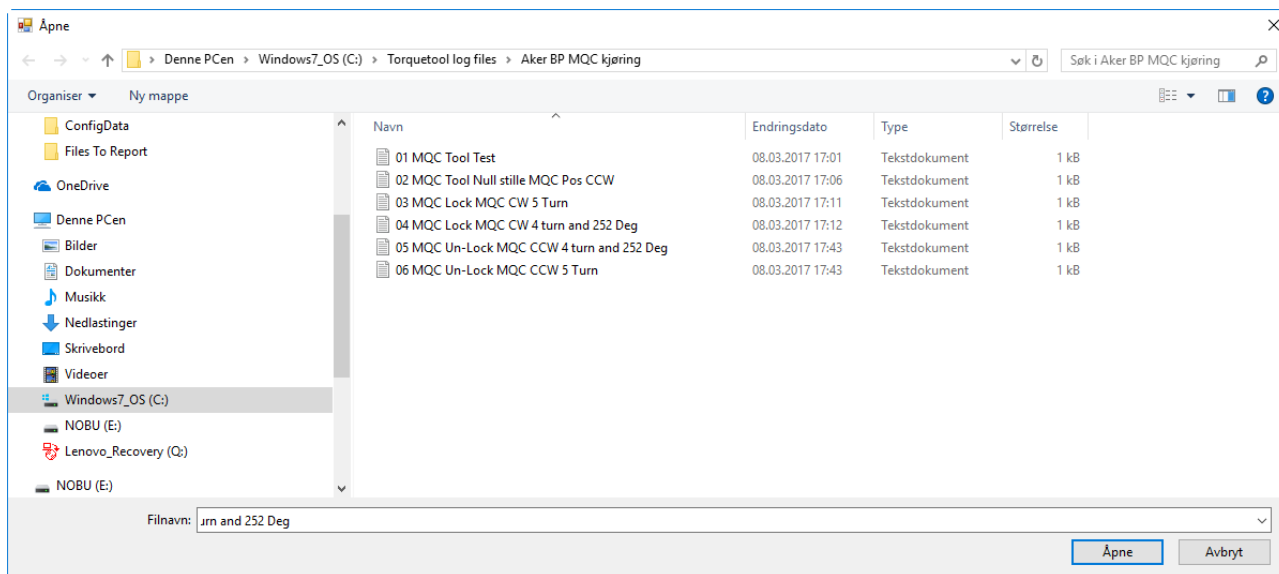

Figure 19: Example files



8. TROUBLE SHOOTING

8.1. GENERAL

In case of loss or bad operation, failure in log file production or GUI application crash, the following are helpful to localize and solve the problems.

8.2. LOSS OF CONFIGURATION

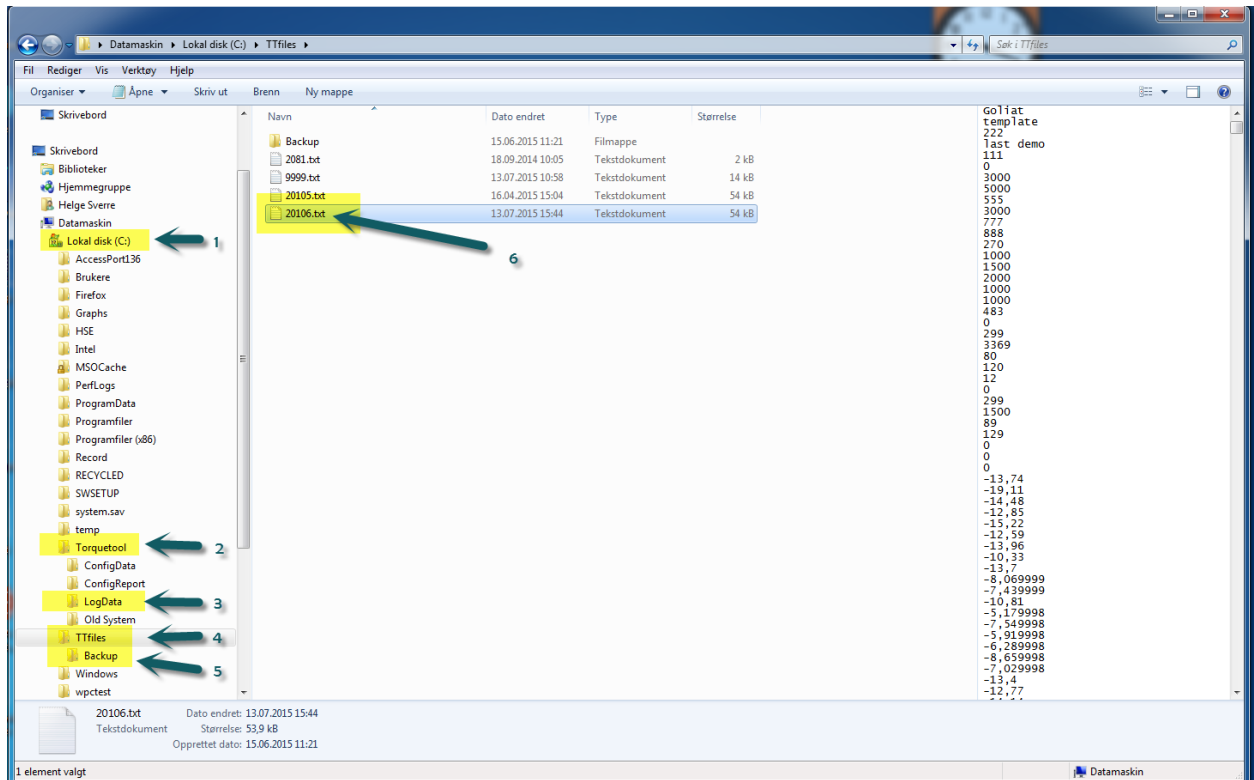
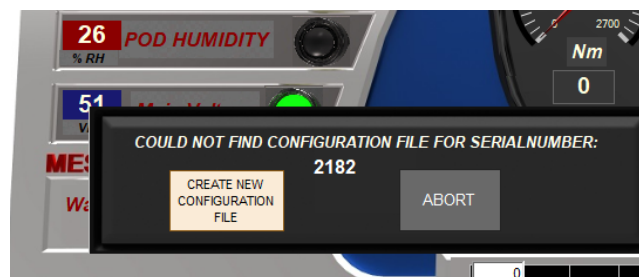

Figure 20: Torque Tool Files

If for any reason the system configuration is lost or corrupt you will not be able to boot the Torque Tool.

The following message will appear:



If a valid Configuration file is present as Backup select “Abort” and follow the instruction.

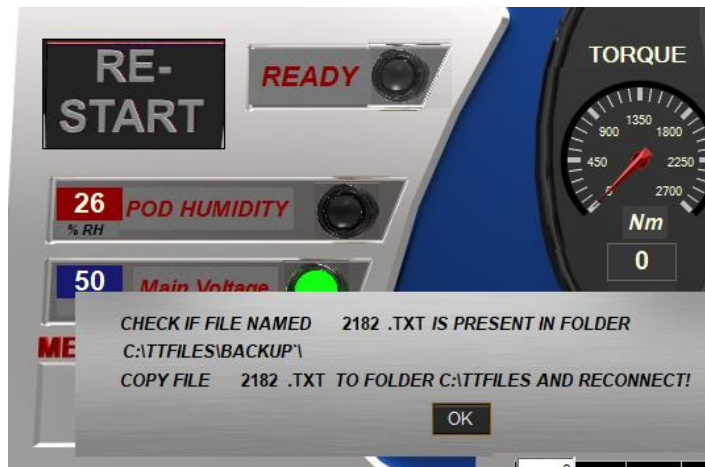

Overwrite the corrupt configuration file using the backup configuration file:

1. From the backup folder, copy the specific torque tool configuration file
2. Paste and overwrite the corrupt configuration file in the TTfiles folder located on the C: drive

NOTE:

The configuration file is named e.g. “20105.txt” as shown in Figure 20. This name is specific for each torque tool

8.2.1. Generate New Backup File

If Backup file are missing or corrupt you need to create new configuration file as follows:

Select “Create new configuration file”. Following window appears:





OPERATION AND MAINTENANCE MANUAL

Alternative 1:

“Load configuration from file” are selected. Main limits will automatically be loaded and can be monitored by entering Setup window. Still, advanced settings need to be manually written.

Alternative 2:

Manually adding Configuration data using setup.

Open Setup window.

Enable write data by selecting “Enable Standard Config”

Followed by valid password. (see section 3.4.1.3)

Write configuration data into all fields including advanced settings.

If Failsafe functions are present, select Enable failsafe config.

Write failsafe config data. And select “Store FS Config”.

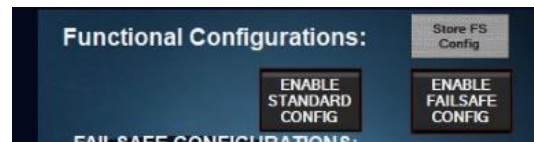

NB! Shaft position sensors calibration will be lost.

Execute shaft position calibration as follows:

Close Setup. Following window will appear blinking



Select Manual mode.

Ensure the tool are equipped with class 3-4 socket, and that

Class 3-4 mode are selected.

Ensure no load at the tool shaft.

Start manual CW operation with speed approx. 200.

After approx. 3 turns the calibration windows will disappear.

Stop operation.

Close GUI.



OPERATION AND MAINTENANCE MANUAL

Setup data and calibration data are now stored in new Configuration file.

Default “Advanced Settings” data:

ALARM THRESHOLD LEVELS:	
POD humidity threshold:	77
Motor temperature threshold:	70
POD temperature threshold:	60
MAIN Under Voltage threshold:	36
Set Ambient Tool Temperature:	20

ENABLE/DISABLE ERROR ALARMS:		
<i>In case of sensor failure you may disable Errors to be able provide preliminary operation until sensor failure correction has taken place.</i>		
	ENABLE	DISABLE
Overvoltage controller:	<input type="radio"/>	<input checked="" type="radio"/>
Undervoltage controller:	<input type="radio"/>	<input checked="" type="radio"/>
Overvoltage Main Supply:	<input type="radio"/>	<input checked="" type="radio"/>
Undervoltage Main Supply:	<input type="radio"/>	<input checked="" type="radio"/>
High temperature Power Electronics (POD):	<input type="radio"/>	<input checked="" type="radio"/>
High temperature Capacitors (POD):	<input type="radio"/>	<input checked="" type="radio"/>
High temperature Ambient POD:	<input type="radio"/>	<input checked="" type="radio"/>
Over speed:	<input type="radio"/>	<input checked="" type="radio"/>

COMMUNICATION TRIP TIME (MS)
1000



8.3. TROUBLE SHOOTING TABLE

Error message/ behaviour	Explanation	Recommended action
Position sensor fault	Occurs if serial communication between POD's controller and position sensor controller are lost or poor. (Sensor failure has no impact).	See section Error! Reference source not found..
Motor overload	Occurs when motor current exceeds current threshold set in POD's controller	See section 8.3.1
Motor over temperature	Occurs when tool temperature exceeds tool temperature threshold. (Typical if tool has reached end stop and continues performing high torque over time).	Measure surface temperature at tool. Is the temperature close to reported motor temperature? Yes: Cool down. No: Change motor <i>over-temperature</i> threshold setting in GUI. OK? No: Motor temperature sensor failure. Change MENC-LS. (Ref. Section 4.1.4; Advanced Settings).
Motor over speed	Occurs if motor speed exceeds the max speed threshold set in POD's controller (Typical reached if spring force rotate rotor with high energy when motor is disabled, or very quick loss of load occurs.	Reduce acceleration and deceleration in Setup OK? No: If possible, reduce set speed and torque to avoid external force back drive. OK? No: Increase parameter 21 (Using MEFCASIM. (Ref. parameter 21 in Extended protocol TT - SEFA protocol v1.1)



Motor Driver tripped	Occurs when motor current exceeds motor Drivers hardware fuse limit.	Reset error. OK? Yes: Reduce performance if possible. OK? No: Follow procedure in section 8.3.1 Reset error OK? No: Power stage failure. Transistor shortened. <i>Note! Frequently repeated errors may cause major control system damage.</i>
Main overvoltage	Occurs if measured main voltage reaches a dangerous high level	Main overvoltage shall not exceed 500VDC. Reduce external back drive force. (Typical valve spring force).
Main undervoltage	Occurs if measured main voltage reaches a dangerous low level	Check Main undervoltage threshold in Setup Advanced settings. OK? No: Check if System power supply are sufficiently dimensioned. 110VAC min.1500W 230VAC min.2000W. OK? No: Increase power supply power or reduce performance settings. OK? No: Check if voltage drops when tool is enabled, but without any load. YES: Hardware fail; CapController No: Check calibration. (Ref. Section 4.1.4; Advanced Settings).



Controller overvoltage	Occurs if measured controller level reaches a dangerous high level	Open POD: Measure MENC- is 24VDC output. OK? YES: Replace Servo controller. OK? No: Replace MENC-ISI.
Controller undervoltage	Occurs if measured controller level reaches a dangerous low level	Open POD: Measure MENC- is 24VDC output. OK? YES: Replace Servo controller. OK? No: Replace MENC-ISI.
Communication lost	Occurs if POD's controller has not received any data from GUI during 1 second after communication is established.	Check system communication device. (Typical MOXA usb/RS232 unit). Are output LED on the device blinking? No: Change unit. OK? Yes: Check communication cable configuration according to wiring diagram. OK? No: Open POD. Measure 24VDC input to Servo controller. Are 24VDC present? Yes: Change Servo controller. No: Change MENC-ISI.



Poor communication	GUI sends approximately 50 data packets per second to POD's controller and POD's controller sends same amount of data packets to GUI. Controller and GUI verifies the data packets validity using Checksum. Number of data packets approved and failed are counted and the percentage of failed packets vs approved are calculated. If the failure percentage reaches a certain level poor communication error are shown and communication are stopped.	Check communication send /receive duration time and fault rate. See section 8.3.2 Check RS232 communication cables shield and ground, and POD shield and ground. OK? NO: Replace system communication device. OK? No: Replace Servo Controller.
Communication failure	If GUI's communication with the topside communication device (port) fails, communication shuts down and communication failure is indicated.	Check port settings in windows device manager. Are Selected Com number present in the device manager? No: Are there any com ports available in device manager? No: Reconnect communication device. OK? No: Update communication device drive and reconnect. OK? Yes: Try to connect with the present Com number. OK? No: Change the communication device and try again.



<p>Data not present in Setup</p>	<p>Configuration file is corrupt. (See section 8.2)</p>	<p>When “connect” is activated “Tool SN-Number” are shown. Open explorer and go to C:\TTfiles”. Open the file with the same name as Tool SN-number. If all numbers on first page are 0, copy the file with the same name from folder C:\TTfiles\Backup. OK? No: Continue and open “Setup”. Write all data manually in setup and close GUI. Reopen GUI and connect.</p>
<p>Class detect failure</p>	<p>No relative deviation between motor position sensor and socket position sensor occurs during class detect operation.</p>	<p>Check that a socket is mounted. OK? Yes: Make sure that tool is turning freely. (No load). OK? Yes: Select class manually. Operate tool and check that position feedback works correctly. OK? Yes: Close GUI. Open GUI and run class detect. OK? No: Open setup and check value in “class detect value”. If 0 increase the value to approx. 40. Try again. OK? No: Increase “class detect value” further. OK? No: Select class manually and run speed in manual. Check that</p>

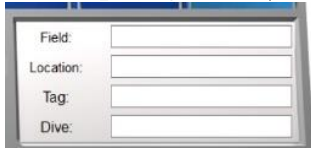

		mechanical position indicator turns. OK? Yes: Check output shaft calibration using calibration GUI. OK? No: Recalibrate output shaft. Yes: Increase further.
Socket position failure (Output shaft position sensor).	When starting and stopping manually or multiturn operation the GUI's position meter performs a jump larger than 1-2 degrees	If motor unit has been opened there is a risk that the output position sensor shaft is mounted 180 degrees offset since calibration was performed. If so, recalibrate output shaft position sensor using calibration GUI. Thereafter a fine position calibration must be performed using the GUI. When this calibration is completed data is stored automatically when GUI is closed.
Failure in Log file production	When operation has been performed and button "Empty current log to file" has been operated no file are generated in folder: E:\Torquetool log files\ (Current date)".	If a character is typed here that is illegal for wiring filename the file generating will be excluded without any notice. Following characters are illegal; \/:*?"<> 



When operation is activated but no torque is output, motion or error message occurs	No failure identified. May be hardware failure, calibration failure or parameter setting failure.	This an abnormal situation where the following action should be taken: If possible, operate output shaft using external force to verify if the position sensor operates correctly and in correct direction. OK? Yes: Open calibration GUI and run; Motor position sensor; “Load graph”. Observe visually that motor turns during this operation.
Motion or torque is performed when communication is lost or disconnected	Failsafe mode are unintentional activated. Motor runs in a given direction using torque and speed values defined in parameters.	Open Setup in GUI and enable failsafe config. Select failsafe mode “Fail as is, motor off”. Close setup and close GUI. Reopen GUI and try again. OK? No: Repeat above.
Motion is performed with fixed speed and only in one direction	May occur as a result of calibration failure.	Serious calibration error; Open calibration GUI and check motor position sensor calibration. OK? Yes: Commutation number may be wrong. Check Commutation number (See section 3.4.1.4 Operation times and Motor data). Is the Commutation number equal to the latest documented Commutation number? No: Type the correct Commutation number (HallCAlibrate using Mefca Simulator) and store. Try again. OK? No:



		Recalibrate. OK? No: Check motor windings. OK? Yes: Try another tool. OK? No: Change Servo controller. OK? No: Change Power stage.
DC-bus voltage drops rapidly when operation mode is activated, and the tool is loaded.	Hardware failure or power supply failure.	Check a different tool system connected to the same power supply. OK? Yes: Probably Cap controller failure. (POD hardware failure)
No error messages, but torque and speed are significant lower than selected limits	Parameter “Max-PWM” may be set low. Reduces general performance	Use MEFCASIM and check parameter Max_PWM. If < 15000 adjust to 15000 press “W1” write and store to flash. Try Again



8.3.1. Motor Overload

1	Check output torque present when overload occurred. If above 2700Nm, reduce torque limit and/or speed, restart and try again. OK? No: run the tool without load for 5 minutes @ speed 2500. Try again. OK?
2	If torque is less than 2600Nm when error occurs check current limit parameters and increase to max. 7800. OK? No: Open calibration GUI. Load graf for Menc-HS. Check deviation. OK?
3	Perform Total calibration. Calibration succeeded? No:
4	Open motor and check magnets regarding metal chips and magnets position. Remove chips and make sure correct position. Calibrate again. OK?
5	Magnet failure or sensor board failure. Load graf when Mag-Sense A are selected. Repeat with mag sense B. Compare graph's with previous stored Mag-Sense graph if possible. Are graph's similar? Yes: Position sensing OK! No: Check rotor friction. OK? Yes: Change magnet. No:
6	Reduce rotor friction to normal and calibrate. OK? No: Change Magnet. OK? No:
7	Check motor winding resistance according to wiring diagram and motor datasheet. OK? No
8	Replace Power stage in POD
(Ref. parameter 22 and 27 in Extended protocol TT - SEFA protocol v1.1)	



8.3.2. Slow Communication

Torque tool communicates at Baud rate 38400. Each command or request packet to/from POD will normally use $((1/38400) * 8 \text{ (bytes)} * 8 \text{ (bits)} * 2(1\text{send}+1\text{receive})) = 3,3\text{ms}$. Processing time in each side need to be added to achieve communication cycle time.

Normal cycle time will be approx. 4-5 milliseconds.

Most commands include speed command (Manual mode) or position command (Multiturn mode).

Following cycle times are estimated to be:

Speed and position command	10 ms. (100 times/sec.)
Torque limit command	150 ms. (6-7 times/sec.)
Speed, position and torque monitor	10 ms. (100 times/sec.)
Warning error update and sensor updates	150 ms. (6-7 times/sec.)

If communication lines are distributed through several converters additional delays may occur. Then if cycle updates appear abnormally slow check communications health and speed by:

Send Faults (%) Number of data packets sent to POD that are not approved by POD. % are number of faults register each 5 second.

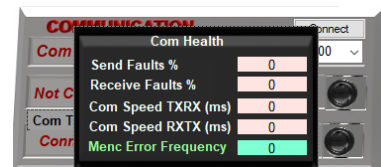

Receive Faults (%) Number of data packets received but not approved by GUI

Com SpeedTXRX (ms) Time from 1 packet are sent from GUI till GUI has received responding packet from POD

Com SpeedRXTX (ms) Time from 1 packet are received from GUI till GUI are sending the following packet



9. LOGISTICS

Verify the following

1. Sender Name and Address clearly visible
2. Receiver Name and address clearly visible
3. Inventory list correct filled out

9.1. HANDLING AND LIFTING

To be lifted in dedicated transportation box. (Fork lift pockets to be used for transportation boxes above 40 Kg).

9.2. TRANSPORTATION

Transport in dedicated transportation box.

9.3. STORAGE

Description
Store the TT system in its dedicated transportation box
Thoroughly coat all exposed surfaces of the Tool with a preservation oil (e.g. WD-40)
Long term storage temperature = 15 deg C



10. MAINTENANCE

The Electric Torque Tool is a simple and robust subsea system with few critical moving parts. There are however a few important inspections points that require attention.

Inspection and maintenance can be performed by the operator, it is however recommended to return the ELTT to Blue Logic for a yearly service, maintenance and calibration.

10.1. DAILY INSPECTION

No.	Description	Check/Verified
01	Perform a visual inspection of ELTT. Special attention should be given to the following: <ul style="list-style-type: none">- ROV Handle Mechanism- Hose/cable- Excessive wear and tear	
02	Flush with fresh water	

10.2. WEEKLEY INSPECTION

No.	Description	Check/Verified
01	Perform a visual inspection of ELTT. Inspect surface treatment and verify no corrosion. Special attention should be given to the following: <ul style="list-style-type: none">- Oil level (1 bar overpressure, refill using the check valve on top of the TT)- Seal areas- ROV Handle- Hose- Fittings- Surface treatment	
02	Flush with fresh water	

10.3. MONTHLY INSPECTION

No special activities are required on a monthly basis. If the Electrical Torque Tool system has been extensively used and repeatedly exposed to dirt and aggressive fluids, pay extra attention to seal areas. Disassemble front socket and clean thoroughly.

**10.4. YEARLY INSPECTION AND MAINTENANCE**

No.	Description	Check/Verified
01	Yearly inspection and maintenance is recommended to be performed by blue Logic. The tool will go through a full teardown and calibration. If available, new software will be installed.	

10.5. LATCH MECHANISM – WEAKLINK REPLACEMENT

No	Description	Check/Verified
01	Remove the six M8x35 Socked Head located at ELTT nose	
02	Remove POM nose	
03	Switch socket to the one desired. Clean socket holder thoroughly	
04	Replace POM nose and bolts. Note: Use Aqua lube and thread lock on bolts before mounting	

11. SUPPORT CONTACT

BLUE LOGIC AS
Forus
Stokkamyrvæien 18
4313 SANDNES
NORWAY

Lars Gunnar Hodnefjell
R&D Manager
Mob: +47 992 63 950
lgh@bluelogic.no